

AIRCAT[®]

PNEUMATIC TOOLS[®]

PRODUCT CATALOG
2020/21

When you've got real work to do.....
Grab hold of an AIRCAT!

AIRCAT
PNEUMATIC TOOLS[®]

NITROCAT
CAUTION XTREME[®]
POWER

VIBROTHERM
by AIRCAT. DRIVE[®]

www.AIRCAT.com



The AIRCAT® line represents the most significant advances in the performance of pneumatic power tools in nearly 30 years. Founded in 1998, our tool line provides substantially reduced noise levels while retaining maximum power and torque. AIRCAT® also incorporates a patented ergonomically engineered handle design to relieve stress and fatigue on the operator's hands, wrists and arms. AIRCAT® has a patented tuned exhaust muffler technology in most tools, which allows discharged air to pass without developing back pressure, thus retaining more power, while significantly reducing noise. More power, Half the noise.

AIRCAT® is committed to product innovation, high quality levels, high service levels and continued development and expansion of the AIRCAT®, NITROCAT® and VIBROTHERM DRIVE® brands.

In late 2018 we introduced a new assortment of VIBROTHERM DRIVE® patented impact wrenches up to 3/4" drive that provide longer working life, lower vibration and shorter length — coupled with "state of the art" cosmetic styling.

In addition the new low weight AIRCAT® 1" impact wrenches provide an unmatched 2,100 ft-lb torque with weights between 13 to 19.9 lbs.

Our ratchet lineup has been expanded to offer extended reach ratchets and sealed flat head ratchets; making the AIRCAT ratchet lineup the broadest in the industry.

The new sander line delivers low noise and vibration levels, low air consumption and unmatched operating comfort at prices that reflect the usual AIRCAT® great value proposition.

TABLE OF CONTENTS

MODEL #	DESCRIPTION	PAGE
3/8" IMPACT WRENCHES		
1320	3/8" BUTTERFLY IMPACT WRENCH	6
1077-TH	3/8" STUBBY IMPACT WRENCH	6
1076-XL	3/8" NITROCAT COMPOSITE COMPACT IMPACT WRENCH	7
1059-VXL	3/8" VIBROTHERM DRIVE COMPOSITE COMPACT IMPACT WRENCH	7
1350-XL	3/8" COMPOSITE HIGH-LOW TORQUE IMPACT WRENCH	8
1300-TH-A	3/8" COMPOSITE IMPACT WRENCH	8
1355-XL	3/8" NITROCAT COMPOSITE IMPACT WRENCH	9
1/2" IMPACT WRENCHES		
1057-TH	1/2" STUBBY IMPACT WRENCH	9
1056-XL	1/2" NITROCAT COMPOSITE COMPACT IMPACT WRENCH	10
1058-VXL	1/2" VIBROTHERM DRIVE COMPOSITE COMPACT IMPACT WRENCH	10
1375-XL	1/2" NITROCAT COMPOSITE IMPACT WRENCH	11
1000-TH	1/2" COMPOSITE IMPACT WRENCH	11
1000-TH-2	1/2" NITROCAT IMPACT WRENCH WITH 2" EXTENDED ANVIL	11
1285-XL	1/2" COMPOSITE IMPACT WRENCH	12
1150	1/2" COMPOSITE IMPACT WRENCH	12
1178-VXL	1/2" VIBROTHERM DRIVE® COMPOSITE IMPACT WRENCH	13
1178-VXL-2	1/2" VIBROTHERM DRIVE® COMPOSITE IMPACT WRENCH W/ 2" EXT ANVIL	13
1200-K	1/2" NITROCAT KEVLAR™ COMPOSITE TWIN CLUTCH IMPACT WRENCH	13
1250-K	1/2" NITROCAT KEVLAR™ COMPOSITE TWIN CLUTCH IMPACT WRENCH	14
1431	1/2" IMPACT WRENCH	14
1431-2	1/2" IMPACT WRENCH WITH 2" EXTENDED ANVIL	14
1450	1/2" IMPACT WRENCH	15
1450-2	1/2" IMPACT WRENCH WITH 2" EXTENDED ANVIL	15
1460-XL	1/2" HIGH AIR PRESSURE IMPACT WRENCH	15
1460-XL-2	1/2" HIGH AIR PRESSURE IMPACT WRENCH WITH 2" EXTENDED ANVIL	15
3/4" IMPACT WRENCHES		
1600-TH-A	3/4" COMPOSITE IMPACT WRENCH	16
1778-VXL	3/4" VIBROTHERM DRIVE® COMPOSITE IMPACT WRENCH	16
1750-K	3/4" NITROCAT KEVLAR™ COMPOSITE TWIN CLUTCH IMPACT WRENCH	17
1680-A	3/4" IMPACT WRENCH	17
1680-A-6	3/4" IMPACT WRENCH WITH 6" ANVIL	17
1777/1777-K	3/4" IMPACT WRENCH	18
1770-XL/1770-XLK	3/4" COMPOSITE IMPACT WRENCH	19
1" IMPACT WRENCHES		
1600-TH-A1	1" COMPOSITE PISTOL GRIP IMPACT WRENCH	20
1870-P	1" SUPER DUTY COMPOSITE PISTOL GRIP IMPACT WRENCH	20
1880-P-A	1" PISTOL GRIP IMPACT WRENCH	21
1890-P	1" TWO JAW PISTOL GRIP IMPACT WRENCH	21
1991	1" STRAIGHT IMPACT WRENCH WITH 6" EXTENDED ANVIL	22
1991-1	1" STRAIGHT IMPACT WRENCH	22
1993-VXL	1" VIBROTHERM DRIVE COMPOSITE STRAIGHT IMPACT WRENCH W/ 6" EXT ANVIL	22
1993-1-VXL	1" VIBROTHERM DRIVE COMPOSITE STRAIGHT IMPACT WRENCH	22
1992	1" STRAIGHT IMPACT WRENCH WITH 8" EXTENDED ANVIL	23
1992-1	1" STRAIGHT IMPACT WRENCH	23
1994	1" SUPER DUTY STRAIGHT IMPACT WRENCH WITH 8" EXTENDED ANVIL	23
1/4" RATCHETS		
807-25	1/4" "MINI" PALM RATCHET	25
800	1/4" COMPOSITE RATCHET	25
804	1/4" RATCHET	25
808-15-25	1/4" LONG REACH RATCHET (15-INCH)	25
3/8" RATCHETS		
807	3/8" "MINI" PALM RATCHET	26
801	3/8" COMPOSITE RATCHET	26
810-RW	3/8" COMPACT IMPACTING RATCHET	26
802	3/8" COMPOSITE RATCHET	26
809-SH	3/8" SEALED FLAT HEAD RATCHET	27
803-RW	3/8" IMPACTING RATCHET	27
806	3/8" RATCHET	27
805-HT	3/8" HIGH TORQUE RATCHET	28
808-15	3/8" LONG REACH RATCHET (15 INCH)	28
808-22	3/8" LONG REACH RATCHET (22 INCH)	28
1/2" RATCHETS		
802-5	1/2" COMPOSITE RATCHET	29
809-SH-5	1/2" SEALED FLAT HEAD RATCHET	29
805-HT-5	1/2" HIGH TORQUE RATCHET	29
GRINDERS & CUT-OFF TOOLS		
6200	.4 HP MINI COMPOSITE STRAIGHT DIE GRINDER	31
6201	.5 HP COMPOSITE STRAIGHT DIE GRINDER	31
6210	.5 HP COMPOSITE EXTENDED STRAIGHT DIE GRINDER	31
6285	.75 HP STRAIGHT DIE GRINDER WITH SPINDLE LOCK	32
6290	.75 HP REVERSIBLE STRAIGHT DIE GRINDER	32

MODEL #	DESCRIPTION	PAGE
GRINDERS & CUT-OFF TOOLS		
6260	1.0 HP COMPOSITE STRAIGHT DIE GRINDER	32
6270	1.0 HP COMPOSITE EXTENDED STRAIGHT DIE GRINDER	33
6255	.4 HP COMPOSITE ANGLE DIE GRINDER	33
6280	.75 HP ANGLE DIE GRINDER WITH SPINDLE LOCK	33
6265	1.0 HP COMPOSITE ANGLE DIE GRINDER	34
6340-A	1.0 HP 4-1/2" ANGLE GRINDER WITH SPINDLE LOCK	34
6380	2.3 HP 5" HEAVY DUTY ANGLE GRINDER WITH SPINDLE LOCK	34
6505	.5 HP 3" COMPOSITE CUT-OFF TOOL	35
6520	.5 HP 3" REVERSIBLE CUT-OFF TOOL	35
6530	.5 HP 3" FLEX HEAD CUT-OFF TOOL	35
6525-A	.6 HP 3" IN-LINE CUT-OFF TOOL	36
6560	1 HP 4" COMPOSITE CUT-OFF TOOL	36
6275-A	1.0 HP 4" INSIDE CUT-OFF TOOL WITH SPINDLE LOCK	36
DRILLS		
4338	.6 HP 3/8" COMPOSITE REVERSIBLE DRILL	38
4450	.6 HP 1/2" COMPOSITE REVERSIBLE DRILL	38
4439	.7 HP 3/8" COMPOSITE REVERSIBLE DRILL	39
4451	.7 HP 1/2" COMPOSITE REVERSIBLE DRILL	39
4337	.75 HP 3/8" ANGLE DRILL	39
HAMMERS		
5100-A-T	.401 SHANK COMPOSITE MEDIUM STROKE AIR HAMMER (TOOL ONLY)	40
5100-A	.401 SHANK COMPOSITE MEDIUM STROKE AIR HAMMER (KIT)	40
5200-A-T	.401 SHANK COMPOSITE LONG STROKE AIR HAMMER	40
5300-A-T	.498 SHANK SUPER DUTY AIR HAMMER (TOOL ONLY)	40
5300-A	.498 SHANK SUPER DUTY AIR HAMMER (KIT)	40
SPECIALTY TOOLS		
6330	18 GAUGE NIBBLER	41
6350	LOW VIBRATION AIR SAW	41
6390	COMPACT NEEDLE SCALER	41
6402	.6 HP 2,600 RPM COMPOSITE TIRE BUFFER	42
6403	.6 HP 3,600 RPM COMPOSITE TIRE BUFFER	42
6400	.75 HP COMPOSITE HIGH SPEED TIRE BUFFER/DRILL	42
SANDERS		
6700-1-332	1" NON VAC 3/32" ORBIT NIB PALM SANDER	44
6700-3-336	3" NON VAC 3/16" ORBIT PALM SANDER	44
6700-3-336-PSA	3" NON VAC 3/16" ORBIT PALM SANDER (PSA PAD)	44
6700-3-336CV	3" CENTRAL VAC 3/16" ORBIT PALM SANDER	44
6700-5-336	5" NON VAC 3/16" ORBIT PALM SANDER	44
6700-5-336CV	5" CENTRAL VAC 3/16" ORBIT PALM SANDER	44
6700-6-332	6" NON VAC 3/32" ORBIT PALM SANDER	44
6700-6-332-PSA	6" NON VAC 3/32" ORBIT PALM SANDER (PSA PAD)	44
6700-6-332CV	6" CENTRAL VAC 3/32" ORBIT PALM SANDER	44
6700-6-332SV	6" SELF VAC 3/32" ORBIT PALM SANDER	44
6700-6-336	6" NON VAC 3/16" ORBIT PALM SANDER	44
6700-6-336-PSA	6" NON VAC 3/16" ORBIT PALM SANDER (PSA PAD)	44
6700-6-336CV	6" CENTRAL VAC 3/16" ORBIT PALM SANDER	44
6700-6-336SV	6" SELF VAC 3/16" ORBIT PALM SANDER	44
6700-6G	6" NON VAC GEARED PLANETARY MOTION SANDER	44
6700-6GCV	6" CENTRAL VAC GEARED PLANETARY MOTION SANDER	44
6700-8G	8" NON VAC GEARED PLANETARY MOTION SANDER	44
6700-8GCV	8" CENTRAL VAC GEARED PLANETARY MOTION SANDER	44
6700-JBS-332	JITTERBUG SANDER	46
6525-ABS	18" BELT SANDER	46
6310	6" COMPOSITE DUAL ACTION SANDER (PSA PAD)	47
6320	SPOT SANDER/POLISHER	47
6370	.6 HP COMPOSITE LOW WEIGHT VERTICAL POLISHER	47
6700-DCE-3	3" NON VAC 3/16" ORBIT DC ELECTRIC PALM SANDER	48
6700-DCE-3V	3" CENTRAL VAC 3/16" ORBIT DC ELECTRIC PALM SANDER VAC	48
6700-DCE-5	5" NON VAC 3/16" ORBIT DC ELECTRIC PALM SANDER	48
6700-DCE-5V	5" CENTRAL VAC 3/16" ORBIT DC ELECTRIC PALM SANDER VAC	48
6700-DCE-6	6" NON VAC 3/16" ORBIT DC ELECTRIC PALM SANDER	48
6700-DCE-6V	6" CENTRAL VAC 3/16" ORBIT DC ELECTRIC PALM SANDER VAC	48
ACCESSORIES		
800-C	45" ADJUSTABLE MECHANICS CREEPER WITH LED LIGHT	49
600-C-25M	1/4" NPT MALE COUPLER WITH MALE AND FEMALE FITTINGS	50
600-C-375M	3/8" NPT MALE COUPLER WITH MALE AND FEMALE FITTINGS	50
600-C-25F	1/4" NPT FEMALE COUPLER WITH MALE AND FEMALE FITTINGS	50
600-C-375M	3/8" NPT FEMALE COUPLER WITH MALE AND FEMALE FITTINGS	50
300-C	AIRCAT MAGNETIC MAT	50
500-C	AIRCAT TOOL BAG	50
	AIRCAT IMPACT BOOTS	51

IMPACT WRENCHES

MORE POWER - LESS NOISE



AIRCAT® offers the most loosening torque in our impact wrench, while only creating 86 dBA of sound, compared to the industry average of 112 dBA. Most

of the Pneumatic Tool industry measures tool performance on power and durability, which AIRCAT® ranks in the top 2 in both categories amongst users.

AIRCAT® offers a large selection of impact wrenches from 3/8" to 1" drive ranging from 80 ft-lb. to 2300 ft-lb. of torque.



AIRCAT IMPACT WRENCH MECHANISMS AND PERFORMANCE CHARACTERISTICS

VIBROTHERM DRIVE® is a new AIRCAT patented mechanism that provides faster blow frequency, high torque, low vibration and a longer working life than other conventional impact wrench mechanisms. In addition, it reduces overall tool length. The cage is driven by the motor that drives the two hammers to generate two blows for each revolution. The elimination of hammer pins and the addition of the front hammer cage plate, that retains the grease within the mechanism, reduces wear within the mechanism increasing working life.

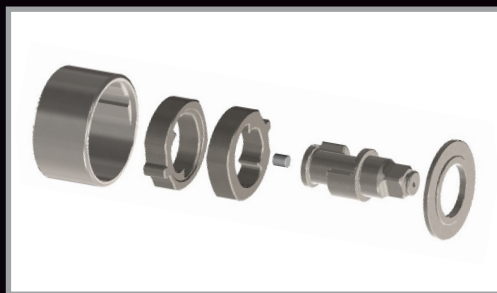

The **TWIN HAMMER** is the most widely used impact wrench mechanism that provides fast blow frequency and high torque. The mechanism is most found in the AIRCAT 3/8", 1/2" and 3/4" impact wrenches. The cage is driven by the motor that drives the twin hammers that rock on hammer pins that pass through the hammer cage to generate two blows for each revolution.



The **PIN-LESS HAMMER** is used in AIRCAT 1" impact wrenches. The PIN-LESS mechanism has a more positive drive and uses fewer moving parts – this design increases reliability for heavy duty applications. The large single hammer provides hard hitting power to achieve rapid high torque. The cage is driven by the motor that drives the large single hammer to generate one hard hitting blow for each revolution.

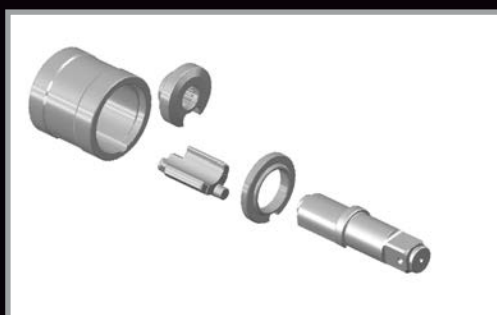

The **TWIN CLUTCH** is featured in NITROCAT 1/2" impact wrenches and 1750-K 3/4" impact wrenches. The twin clutch is specifically designed to provide smooth and powerful operation and to create high initial torque. This mechanism outperforms other mechanism in high torque engine service and repair work, and particularly for removal of stubborn crank shaft bolts. When the hammer rotates past the anvil, a ball pushes the pins forward engaging them with the anvil, the pins are then pushed backwards by the spring. This mechanism has very fast acceleration that creates the high initial torque.

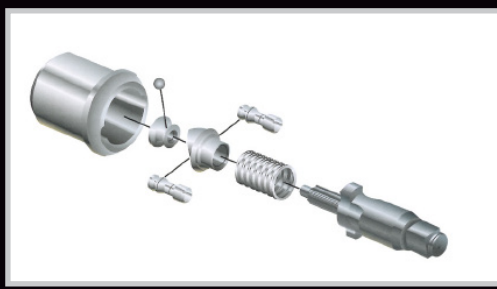

The **JUMBO HAMMER** is used in AIRCAT and NITROCAT compact impact wrenches. The JUMBO hammer enables AIRCAT to provide high torque and high reliability in its smallest impact wrenches. The cage is driven by the motor that drives the single JUMBO hammer that rocks on hammer pins that pass through the hammer cage to generate one hard hitting blow for each revolution.



The **TWO JAW CLUTCH** is featured exclusively in the AIRCAT 1890-P 1" Pistol Grip Impact Wrench. The TWO JAW clutch provides unparalleled torque output and longer life than any other mechanism. The cage is driven by the motor and the jaws on the cage directly drive the anvil. This action eliminates the customary hammering, increasing torque and reducing wear. The internal spring then disengages the jaws to turn to the next drive cycle. The mechanism is ideal for heavy duty off road vehicle work and steel erection.



IMPACT WRENCHES

1320 **3/8" BUTTERFLY IMPACT WRENCH**



- Provides 80 ft-lb of maximum torque and 100 ft-lb of loosening torque
- Weighing only 1.1 lb. and with an overall length of only 5.4", it fits comfortably in the operator's palm
- Ideal for work around radiators and in other space restricted areas
- Features a three position built-in power management switch for control on the job
- Built-in swivel air inlet increases maneuverability and access to restricted work areas
- Twin hammer mechanism reduces vibration while increasing reliability



1077-TH **3/8" STUBBY IMPACT WRENCH**



- Provides 500 ft-lb of maximum torque and 700 ft-lb of loosening torque
- Only 3.85" overall length
- Low weight aluminum alloy housing
- Reliable Jumbo hammer mechanism delivers maximum power while increasing reliability
- Patented "Silencing Technology" reduces the noise level to (89 dBA)
- Trigger mounted combined forward/reverse and power management switch provides ultimate control and one-hand operation



1057-THBB
Black AIRCAT® Boot
Fits Models: 1077-TH and 1057-TH

SPECIFICATIONS

Model No.	Free Speed (RPM)	Bolt Capacity (in.)	Square Drive (in.)	Impacts Per Minute	Max Torque (ft-lb)	Weight (lbs.)	Length (in)	Air Cons. (CFM)	Rec. Hose Size (in.)	Air Inlet NPT (in.)
1320	10,000	1/2	3/8	1800	80	1.1	5.4	8	3/8	1/4
1077-TH	9,000	1/2	3/8	1600	500	2.80	3.85	6	3/8	1/4



1076-XL 3/8" NITROCAT COMPOSITE COMPACT IMPACT WRENCH

- Provides 550 ft-lb maximum torque and 750 ft-lb of loosening torque
- Low weight composite housing reduces weight to 2.5 Lbs.
- Reliable jumbo hammer mechanism delivers maximum power, while increasing reliability
- Patented "Silencing Technology" reduces the noise level to (85 dBA)
- Patented grip has been ergonomically designed to perfectly fit the hand, providing unmatched comfort for the user
- Patented trigger mounted combined forward/reverse and power management switch provides ultimate control and one-hand operation



1056-XLBB
Black AIRCAT® Boot
Fits Models: 1076-XL and 1056-XL



1059-VXL 3/8" VIBROTHERM DRIVE® COMPOSITE COMPACT IMPACT WRENCH

- Provides 550 ft-lb maximum torque and 750 ft-lb of loosening torque
- VIBROTHERM DRIVE® impact wrenches incorporates the new patented AIRCAT design impact wrench mechanism
- The new mechanism reduces vibration levels by 30%-40% and increases the life of the mechanism by 50%
- The latest patented AIRCAT muffler system provides the AIRCAT's unmatched low noise levels
- The patented grip design provides the customary AIRCAT operator comfort
- Investment in tooling, materials, and the triple injection molding processes enables AIRCAT® to produce cosmetic designs that are unmatched in the industry



1058-VXLBB
Black AIRCAT® Boot
Fits Models: 1059-VXL and 1058-VXL

SPECIFICATIONS

Model No.	Free Speed (RPM)	Bolt Capacity (in.)	Square Drive (in.)	Impacts Per Minute	Max. Torque (ft-lb) @90 psi	Weight (lbs.)	Length (in)	Air Cons. (CFM)	Rec. Hose Size (in.)	Air Inlet NPT (in.)
1076-XL	9,000	9/16	3/8	1650	550	2.5	4.25	8	3/8	1/4
1059-VXL	9,000	9/16	3/8	1700	550	2.8	4.4	8	3/8	1/4

IMPACT WRENCHES



1350-XL **3/8" COMPOSITE** **HIGH-LOW TORQUE IMPACT WRENCH**

- Provides 500 ft-lb maximum torque and 600 ft-lb of loosening torque
- Refined design twin hammer increases blow frequency and efficiency while reduces wear
- Unique High-Low torque switch for instant change of power in forward and reverse provides one hand operation
- Molded buffers protects tool from side impact
- Ergonomically designed grip and trigger provide ultimate operating comfort
- Push button forward/reverse



1300-TH-A **3/8" COMPOSITE IMPACT WRENCH**

- Provides 450 ft-lb maximum torque and 600 ft-lb of loosening torque
- "Super Clutch" Twin Hammer Mechanism
- Durable composite housing
- Patented ergonomically designed housing
- Patented quiet tuned exhaust (86 dBA)
- Patented easy operation flip lever forward and reverse



1300-THBB
Black AIRCAT® Boot
Fits Model: 1300-TH and 1300-TH-A

SPECIFICATIONS

Model No.	Free Speed (RPM)	Bolt Capacity (in.)	Square Drive (in.)	Impacts Per Minute	Max. Torque (ft-lb) @90 psi	Weight (lbs.)	Length (in)	Air Cons. (CFM)	Rec. Hose Size (in.)	Air Inlet NPT (in.)
1350-XL	10,000	1/2	3/8	1700	500	3.15	6.3	6	3/8	1/4
1300-TH-A	10,000	1/2	3/8	1750	450	2.63	6.75	6	3/8	1/4

3/8" - 1/2"



1355-XL 3/8" NITROCAT® COMPOSITE IMPACT WRENCH

- Provides 500 ft-lb maximum torque and 700 ft-lb of loosening torque
- The NitroCat 1355-XL is a no non-sense, hard hitting 3/8" impact wrench that incorporates a twin hammer mechanism
- Provides all the torque you need and tremendous speed to get the job done
- Patented quiet tuned exhaust (86 dBA)
- Patented easy operation flip lever forward and reverse
- Durable Kevlar™ reinforced "Body Armour" housing
- Great for brake calipers and transmission work



1355-XLBR
Red Flame Nitrocat® Boot
Fits Models: 1375-XL and 1355-XL

1057-TH 1/2" STUBBY IMPACT WRENCH



- Provides 500 ft-lb of maximum torque and 700 ft-lb of loosening torque
- Only 3.85" overall length
- Low weight aluminum alloy housing
- Reliable Jumbo hammer mechanism delivers maximum power, while increasing reliability
- Patented "Silencing Technology" reduces the noise level to (89 dBA)
- Trigger mounted combined forward/reverse and power management switch provides ultimate control and one-hand operation



1057-THBB
Black AIRCAT® Boot
Fits Models: 1077-TH and 1057-TH

SPECIFICATIONS

Model No.	Free Speed (RPM)	Bolt Capacity (in.)	Square Drive (in.)	Impacts Per Minute	Max. Torque (ft-lb) @90 psi	Weight (lbs.)	Length (in)	Air Cons. (CFM)	Rec. Hose Size (in.)	Air Inlet NPT (in.)
1355-XL	10,000	1/2	3/8	1350	500	2.75	6.0	6	3/8	1/4
1057-TH	9,000	1/2	1/2	1600	500	2.80	3.85	6	3/8	1/4

IMPACT WRENCHES



1056-XL

1/2" NITROCAT COMPOSITE COMPACT IMPACT WRENCH

- Provides 550 ft-lb maximum torque and 750 ft-lb of loosening torque
- Low weight composite housing reduces weight to 2.5 Lbs.
- Reliable jumbo hammer mechanism delivers maximum power, while increasing reliability
- Patented "Silencing Technology" reduces the noise level to (85 dBA)
- Patented grip has been ergonomically designed to perfectly fit the hand, providing unmatched comfort for the user
- Patented trigger mounted combined forward/reverse and power management switch provides ultimate control and one-hand operation



1056-XLBB
Black AIRCAT® Boot
Fits Models: 1056-XL and 1076-XL



1058-VXL

1/2" VIBROTHERM DRIVE® COMPOSITE COMPACT IMPACT WRENCH

- Provides 550 ft-lb maximum torque and 750 ft-lb of loosening torque
- VIBROTHERM DRIVE® impact wrenches incorporates the new patented AIRCAT design impact wrench mechanism
- The new mechanism reduces vibration levels by 30%-40% and increases the life of the mechanism by 50%
- The latest patented AIRCAT muffler system provides the AIRCAT's unmatched low noise levels (85 dBA)
- The patented grip design provides the customary AIRCAT operator comfort
- Investment in tooling, materials, and the triple injection molding processes enables AIRCAT® to produce cosmetic designs that are unmatched in the industry



1058-VXLBB
AIRCAT® VIBROTHERM DRIVE® Boot
Fits Models: 1059-VXL and 1058-VXL

SPECIFICATIONS

Model No.	Free Speed (RPM)	Bolt Capacity (in.)	Square Drive (in.)	Impacts Per Minute	Max Torque (ft-lb)	Weight (lbs.)	Length (in)	Air Cons. (CFM)	Rec. Hose Size (in.)	Air Inlet NPT (in.)
1056-XL	9,000	9/16	1/2	1650	550	2.5	4.25	8	3/8	1/4
1058-VXL	9,000	9/16	1/2	1700	550	2.8	4.4	8	3/8	1/4



1375-XL 1/2" NITROCAT® COMPOSITE IMPACT WRENCH

- Provides 500 ft-lb maximum torque and 700 ft-lb of loosening torque
- The NitroCat 1375-XL is a no non-sense, hard hitting 1/2" impact wrench that incorporates a twin hammer mechanism
- Provides all the torque you need and a tremendous speed to get the job done
- Patented quiet tuned exhaust (86 dBA)
- Patented easy operation flip lever forward and reverse
- Great for brake calipers, transmission work
- Durable Kevlar™ reinforced "Body Armour" housing



1000-TH 1/2" COMPOSITE IMPACT WRENCH 1000-TH-2 1/2" COMPOSITE IMPACT WRENCH WITH 2" EXTENDED ANVIL

- Provides 800 ft-lb maximum torque and 1,000 ft-lb of loosening torque
- "Super Clutch" twin hammer mechanism
- Durable composite housing
- Patented ergonomically designed handle
- Patented quiet tuned exhaust (86 dBA)
- Patented easy operation flip lever forward and reverse



1150-BB
Black AIRCAT® Boot
Fits Models: 1150,
1000-TH and 1000-TH-2

SPECIFICATIONS

Model No.	Free Speed (RPM)	Bolt Capacity (in.)	Square Drive (in.)	Impacts Per Minute	Max. Torque (ft-lb)	Weight (lbs.)	Length (in)	Air Cons. (CFM)	Rec. Hose Size (in.)	Air Inlet NPT (in.)
1375-XL	10,000	1/2	1/2	1350	500	2.75	6.0	6	3/8	1/4
1000-TH	8,000	9/16	1/2	1300	800	4.50	7.5	8	3/8	1/4
1000-TH-2	8,000	9/16	1/2 x 2	1300	800	4.75	9.5	8	3/8	1/4

IMPACT WRENCHES



1285-XL **1/2" COMPOSITE IMPACT WRENCH**

- 900 ft-lb maximum torque and 1,100 ft-lb loosening torque
- Hard hitting twin hammer mechanism delivers maximum power
- Grip has been ergonomically designed to perfectly fit the hand-providing unmatched comfort for the user
- Molded buffers protect the tool from side impacts
- Push button forward/reverse buttons for fast and convenient change of direction
- Power management switch provides ultimate control



1150 **1/2" COMPOSITE IMPACT WRENCH**

- Provides 900 ft-lb maximum torque and 1,295 ft-lb of loosening torque
- Most powerful 1/2" impact in it's class!
- Hard hitting twin hammer mechanism
- Durable composite housing
- Patented ergonomically designed handle
- Patented quiet tuned exhaust (86 dBA)
- Patented easy operation flip lever forward and reverse



1150-BB
Black AIRCAT® Boot
Fits Models: 1150, 1000-TH and 1000-TH-2

SPECIFICATIONS

Model No.	Free Speed (RPM)	Bolt Capacity (in.)	Square Drive (in.)	Impacts Per Minute	Max. Torque (ft-lb)	Weight (lbs.)	Length (in)	Air Cons. (CFM)	Rec. Hose Size (in.)	Air Inlet NPT (in.)
1285-XL	7,500	9/16	1/2	1600	900	4.6	6.66	8	3/8	1/4
1150	9,000	9/16	1/2	1400	900	4.5	7.5	8	3/8	1/4

1/2"

VIBROTHERM
by AIRCAT DRIVE



1178-VXL
1/2" VIBROTHERM DRIVE®
COMPOSITE IMPACT WRENCH
1178-VXL-2

1/2" VIBROTHERM DRIVE® COMPOSITE IMPACT WRENCH WITH 2" EXTENDED ANVIL

- Provides 950 ft-lb maximum torque and 1,300 ft-lb of loosening torque
- VIBROTHERM DRIVE® impact wrenches incorporates the new patented AIRCAT design impact wrench mechanism
- The new mechanism reduces vibration levels by 30%-40% and increases the life of the mechanism by 50%
- The latest patented AIRCAT muffler system provides the AIRCAT's unmatched low noise levels (86 dBA)
- The patented grip design provides the customary AIRCAT® operator comfort



1178-VXLBB
AIRCAT® VIBROTHERM DRIVE® Boot
Fits model: 1178-VXL, 1178-VXL-2

NITROCAT
Xtreme Power



1200-K
1/2" NITROCAT KEVLAR™ COMPOSITE
TWIN CLUTCH IMPACT WRENCH

- Provides 900 ft-lb maximum torque and 1,295 ft-lb of loosening torque
- The NitroCat 1200-K is a no non-sense, hard hitting 1/2" impact wrench that out performs anything in its class!
- Hard hitting smooth twin clutch mechanism
- Durable Kevlar™ reinforced "Body Armor" housing
- Patented ergonomically designed handle
- Patented quiet tuned exhaust (86 dBA)
- Patented easy operation flip lever forward and reverse
- The twin clutch is better suited for heavy duty (frame work, medium to heavy duty trucks)



1200-KBR
Red Flame NITROCAT® Boot
Fits model: 1200-K

SPECIFICATIONS

Model No.	Free Speed (RPM)	Bolt Capacity (in.)	Square Drive (in.)	Impacts Per Minute	Max. Torque (ft-lb)	Weight (lbs.)	Length (in)	Air Cons. (CFM)	Rec. Hose Size (in.)	Air Inlet NPT (in.)
1178-VXL	7,500	9/16	1/2	1400	950	4.5	6.4	8	3/8	1/4
1178-VXL-2	7,500	9/16	1/2	1400	950	4.7	8.4	8	3/8	1/4
1200-K	8,000	9/16	1/2	950	900	4.5	8.25	8	3/8	1/4

IMPACT WRENCHES



1250-K 1/2" NITROCAT KEVLAR™ COMPOSITE TWIN CLUTCH IMPACT WRENCH

- Provides 950 ft-lb maximum torque and 1,300 ft-lb of loosening torque
- The NITROCAT 1250-K is a fearless, hard hitting, 1/2" impact wrench that outperforms anything in its class!
- Hard hitting smooth twin clutch mechanism
- Durable Kevlar™ reinforced "Body Armor" housing
- Patented ergonomically designed handle
- Patented quiet tuned exhaust (86 dBA)
- Patented easy operation flip lever forward and reverse
- The twin clutch is better suited for heavy duty (frame work, medium to heavy duty trucks)



1250-KBB
Nitrocat® Black Boot
Fits model: 1250-K



1431 1/2" IMPACT WRENCH 1431-2

1/2" IMPACT WRENCH WITH 2" EXTENDED ANVIL

- Provides 800 ft-lb maximum torque and 1,000 ft-lb of loosening torque
- Hard hitting twin hammer mechanism delivers maximum power
- Grip is ergonomically designed to perfectly fit the hand, providing unmatched comfort for the user
- Cross bolt forward/reverse and power management control
- Triple heat treated Ni-Cr-Mo alloy steel hammer mechanism parts and anvil provide ultimate reliability



1431-2 2" Extended Anvil
Includes 1 each.
Grey Pneumatic® Thin Wall Flip
Socket (19mm / 21 mm)



SPECIFICATIONS

Model No.	Free Speed (RPM)	Bolt Capacity (in.)	Square Drive (in.)	Impacts Per Minute	Max. Torque (ft-lb)	Weight (lbs.)	Length (in)	Air Cons. (CFM)	Rec. Hose Size (in.)	Air Inlet NPT (in.)
1250-K	8,500	9/16	1/2	1000	950	4.5	8.25	8	3/8	1/4
1431	9,000	1/2	1/2	1600	800	5.7	7.20	8	3/8	1/4
1431-2	9,000	1/2	1/2 x 2	1600	800	6.0	9.20	8	3/8	1/4



1450 **1/2" IMPACT WRENCH**

1450-2 **1/2" IMPACT WRENCH WITH 2" EXTENDED ANVIL**

- Provides 800 ft-lb maximum torque and 1,000 ft-lb of loosening torque
- Refined design twin hammer increases blow frequency and efficiency
- Very fast torque development
- 9,000 RPM Free speed provides fast run-down
- Ergonomically designed grip provides maximum operating comfort
- Six position power management switch in back cap provides ultimate control
- Brushed aluminum housing



1460-XL **1/2" HIGH AIR PRESSURE IMPACT WRENCH**

1460-XL-2 **1/2" HIGH AIR PRESSURE IMPACT WRENCH WITH 2" EXTENDED ANVIL**

- Provides 725 ft-lb maximum torque and 900 ft-lb of loosening torque
- Hard hitting twin hammer mechanism
- Designed for tire shops to operate up to 125 psi air pressure
- Improved design ergonomic grip provides maximum operating comfort
- Molded motor housing cover protects the tool and adds reliability
- Cross bolt style forward/reverse with built-in regulator
- Triple heat treated alloy steel hammers, hammer cage and anvil
- Reliable throttle design with tease trigger

SPECIFICATIONS

Model No.	Free Speed (RPM)	Bolt Capacity (in.)	Square Drive (in.)	Impacts Per Minute	Max. Torque (ft-lb)	Weight (lbs.)	Length (in)	Air Cons. (CFM)	Rec. Hose Size (in.)	Air Inlet NPT (in.)
1450	9,000	9/16	1/2	1200	800	4.9	7.0	8	3/8	1/4
1450-2	9,000	9/16	1/2 x 2	1200	800	5.1	9.0	8	3/8	1/4
1460-XL	9,600	9/16	1/2	1600	725	5.75	7.25	8	3/8	1/4
1460-XL-2	9,600	9/16	1/2 x 2	1600	725	6.0	9.25	8	3/8	1/4

IMPACT WRENCHES



1600-TH-A 3/4" COMPOSITE IMPACT WRENCH

- Provides 1,400 ft-lb maximum torque and 1,600 ft-lb of loosening torque
- Hard hitting "Super Clutch" twin hammer mechanism
- Best suited for bus/large automotive use, large agricultural service vehicles, large bolt assembly
- Patented ergonomically designed handle
- Patented quiet tuned exhaust (86 dBA)
- Patented easy operation flip lever forward and reverse
- Combined through hole and friction ring socket retainer



1600-THBB
Black Aircat® Boot
Fits Models: 1600-TH, 1600-TH-A
and 1600-TH-A1



1778-VXL 3/4" VIBROTHERM DRIVE® COMPOSITE IMPACT WRENCH

- Provides 1,450 ft-lb maximum torque and 1,700 ft-lb of loosening torque
- VIBROTHERM DRIVE® impact wrenches incorporates the new patented AIRCAT design impact wrench mechanism
- The new mechanism reduces vibration levels by 30%-40% and increases the life of the mechanism by 50%
- The latest patented AIRCAT muffler system provides the AIRCAT's unmatched low noise levels
- The patented grip design provides the customary AIRCAT operator comfort
- Investment in tooling, materials, and the triple injection molding processes enables AIRCAT® to produce cosmetic designs that are unmatched in the industry



1778-VXLB
AIRCAT® VIBROTHERM DRIVE® Boot
Fits Model: 1778-VXL

SPECIFICATIONS

Model No.	Free Speed (RPM)	Bolt Capacity (in.)	Square Drive (in.)	Impacts Per Minute	Max. Torque (ft-lb) @90 psi	Weight (lbs.)	Length (in)	Air Cons. (CFM)	Rec. Hose Size (in.)	Air Inlet NPT (in.)
1600-TH-A	4,500	7/8	3/4	900	1400	8.1	9.25	10	1/2	3/8
1778-VXL	5,400	1	3/4	1300	1450	7.4	7.4	8	1/2	3/8



1750-K 3/4" NITROCAT® KEVLAR™ COMPOSITE TWIN CLUTCH IMPACT WRENCH

- Provides 1,300 ft-lb maximum torque and 1,500 ft-lb of loosening torque
- Smooth twin clutch mechanism for fast torque build-up and low vibration
- Durable Kevlar™ reinforced "Body Armor" housing
- Patented "silencing technology" reduces noise to (90 dBA)
- Patented ergonomic grip for comfort
- Combined through hole and friction ring socket retainer



1680-A 3/4" IMPACT WRENCH 1680-A-6 3/4" IMPACT WRENCH WITH 6" ANVIL

- Provides 1,400 ft-lb maximum torque and 1,600 ft-lb of loosening torque
- Durable hard hitting twin hammer mechanism
- Improved compact design
- Patented "Silencing Technology" reduces noise to (89 dBA)
- Patented AIRCAT grip
- Combined power management forward/reverse switch
- Triple heat treated Ni-Cr-Mo alloy steel hammer mechanism
- Designed for the very toughest working conditions
- Combined through hole and friction ring socket retainer

SPECIFICATIONS

Model No.	Free Speed (RPM)	Bolt Capacity (in.)	Square Drive (in.)	Impacts Per Minute	Max. Torque (ft-lb) @90 psi	Weight (lbs.)	Length (in)	Air Cons. (CFM)	Rec. Hose Size (in.)	Air Inlet NPT (in.)
1750-K	4,500	7/8	3/4	1000	1300	9	9.75	8	1/2	3/8
1680-A	4,500	1	3/4	950	1400	12.5	8.9	8	1/2	3/8
1680-A-6	4,500	1	3/4 X 6	950	1400	14.8	14.8	8	1/2	3/8

IMPACT WRENCHES



1777 3/4" IMPACT WRENCH

- Provides 1,400 ft-lb maximum torque and 1,600 ft-lb of loosening torque
- Refined design twin hammer increases blow efficiency and increases hammer mechanism life
- Hammer parts are made from triple heat treated Ni-cr-mo alloy steel for ultimate reliability
- Improved design ergonomic grip for maximum operating comfort
- Very fast torque development
- Combined six position power management and reverse knob for ultimate control

1777-K 3/4" IMPACT WRENCH KIT

Includes: 1777 3/4" Impact Wrench, AIRCAT® Tool Bag and Grey Pneumatic 3/4-in. Drive "Deep Length" Impact Socket Set
Socket Sizes: 1", 1-1/16", 1-1/8", 1-1/4", 1-5/16", 1-3/8", 1-7/6" and 1-1/2"



SPECIFICATIONS

Model No.	Free Speed (RPM)	Bolt Capacity (in.)	Square Drive (in.)	Impacts Per Minute	Max. Torque (ft-lb) @90 psi	Weight (lbs.)	Length (in)	Air Cons. (CFM)	Rec. Hose Size (in.)	Air Inlet NPT (in.)
1777 1777-K	6500	1	3/4	1600	1400	7.5	8.1	8	1/2	3/8



1770-XL 3/4" COMPOSITE IMPACT WRENCH

- Provides 1,400 ft-lb maximum torque and 1,600 ft-lb of loosening torque
- Refined design twin hammer increases blow frequency and efficiency
- Power management switch with three power settings
- Molded-in buffers protect tool from side impact
- Ergonomically designed grip and trigger provide ultimate operating comfort
- Designed for heavy duty fleet maintenance and industrial MRO work
- Combined through hole and friction ring socket retainer



1770-XLBB
Black AIRCAT® Boot
Fits Model: 1770-XL

1770-XLK 3/4" IMPACT WRENCH KIT

Includes: 1770-XL 3/4" Impact Wrench, AIRCAT® Tool Bag and Grey Pneumatic 3/4-in. Drive "Deep Length" Impact Socket Set
Socket Sizes: 1", 1-1/16", 1-1/8", 1-1/4", 1-5/16", 1-3/8", 1-7/6" and 1-1/2"



SPECIFICATIONS

Model No.	Free Speed (RPM)	Bolt Capacity (in.)	Square Drive (in.)	Impacts Per Minute	Max. Torque (ft-lb) @90 psi	Weight (lbs.)	Length (in)	Air Cons. (CFM)	Rec. Hose Size (in.)	Air Inlet NPT (in.)
1770-XL 1770-XLK	6,500	1	3/4	1300	1400	7.4	8.25	8	1/2	3/8

IMPACT WRENCHES



1600-TH-A1 **1" COMPOSITE PISTOL GRIP** **IMPACT WRENCH**

- Provides 1,400 ft-lb maximum torque and 1,600 ft-lb of loosening torque
- Hard hitting "Super Clutch" twin hammer mechanism
- Patented ergonomically designed handle
- Patented quiet tuned exhaust (86 dBA)
- Patented easy operation flip lever forward and reverse
- Combined through hole and friction ring socket retainer
- Best suited for bus/large automotive use, large agricultural service vehicles, large bolt assembly



1600-THBB
Black Aircat® Boot
Fits Models: 1600-TH, 1600-TH-A
and 1600-TH-A1



1870-P **1" SUPER DUTY COMPOSITE** **PISTOL GRIP IMPACT WRENCH**

- Provides 1,900 ft-lb maximum torque and 2,100 ft-lb of loosening torque
- Unmatched power to weight ratio – weighs only 12.95 lbs.
- Low weight impact-resistant housing
- Features combined friction-ring and through-hole socket retainers
- Offset side handle design prevents operators hand getting too close to work area

SPECIFICATIONS

Model No.	Free Speed (RPM)	Bolt Capacity (in.)	Square Drive (in.)	Impacts Per Minute	Max. Torque (ft-lb) @90 psi	Weight (lbs.)	Length (in)	Air Cons. (CFM)	Rec. Hose Size (in.)	Air Inlet NPT (in.)
1600-TH-A1	4,500	1-1/4	1	1100	1400	8.25	9.25	10	1/2	3/8
1870-P	7,500	1-1/4	1	1900	2100	12.95	10.7	10.5	1/2	1/2

1" PISTOL



1880-P-A **1" PISTOL GRIP IMPACT WRENCH**

- Provides 1,700 ft-lb maximum torque and 1,900 ft-lb of loosening torque
- Hard hitting pin-less hammer mechanism
- Molded hammer case protective cover
- Uniquely designed combined rear protective gasket/band prevents band from moving out of position
- Rugged bolt-on side assist handle
- Low wear pin-less hammer
- Noise level to (88 dBA)
- Combined forward/reverse power management switch provides better control
- Combined through hole and friction ring socket retainer



1890-P **1" TWO JAW PISTOL GRIP IMPACT WRENCH**

- Provides 2,000 ft-lb maximum torque and 2,500 ft-lb of loosening torque
- Two jaw clutch provides unparalleled torque output and increases the life of the hammer beyond other impact mechanisms
- The two jaw clutch does not waste energy. This combined with the precision air motor dramatically reduces air consumption over other 1" impact wrenches to 24.5 CFM free running and 6 average
- Designed for fleet and off road vehicle service and steel erection
- Steel hammer case and heavy duty cast housing handle provide ultimate reliability
- Combined through hole and friction ring socket retainer

SPECIFICATIONS

Model No.	Free Speed (RPM)	Bolt Capacity (in.)	Square Drive (in.)	Impacts Per Minute	Max. Torque (ft-lb) @90 psi	Weight (lbs.)	Length (in)	Air Cons. (CFM)	Rec. Hose Size (in.)	Air Inlet NPT (in.)
1880-P-A	4,800	1-1/4	1	900	1700	23.5	11.75	16	1/2	1/2
1890-P	4,200	1-1/4	1	1200	2000	24.0	11.0	6	1/2	1/2

IMPACT WRENCHES

1991

1" STRAIGHT IMPACT WRENCH WITH 6" EXTENDED ANVIL

- Provides 2,100 ft-lb maximum torque and 2,300 ft-lb of loosening torque
- Unmatched power to weight ratio
- Exhaust can be located at either the top or bottom of tool
- Rubber handle grips and rubberized trigger inserts for ultimate comfort
- Combined friction-ring and through-hole socket retainers



1991 Includes Grey Pneumatic® Sockets (33mm \ 1-1/2-in)



1991-1

1" STRAIGHT IMPACT WRENCH



1993-VXL

1" VIBROTHERM DRIVE® COMPOSITE STRAIGHT IMPACT WRENCH WITH 6" ANVIL

- Provides 2,100 ft-lb maximum torque and 2,300 ft-lb of loosening torque
- VIBROTHERM DRIVE® impact wrenches incorporates the new patented AIRCAT® design impact wrench mechanism
- The new mechanism reduces vibration levels by 30%-40% and increases the life of the mechanism by 50%
- 6,000 RPM Free Speed
- Unmatched power-to-weight ratio
- Rubber handle grip and rubberized trigger inserts for ultimate comfort
- Combined friction-ring and through-hole socket retainer
- Investment in tooling, materials, and the triple injection molding processes enables AIRCAT® to produce cosmetic designs that are unmatched in the industry



1993-1-VXL

1" VIBROTHERM DRIVE® COMPOSITE STRAIGHT IMPACT WRENCH

SPECIFICATIONS

Model No.	Free Speed (RPM)	Bolt Capacity (in.)	Square Drive (in.)	Impacts Per Minute	Max. Torque (ft-lb) @90 psi	Weight (lbs.)	Length (in)	Air Cons. (CFM)	Rec. Hose Size (in.)	Air Inlet NPT (in.)
1991	6,000	1-1/4	1 x 6	1600	2100	20.7	19.0	8	1/2	1/2
1991-1	6,000	1-1/4	1	1600	2100	16.7	12.9	8	1/2	1/2
1993-VXL	6,000	1-1/4	1 x 6	950	2100	20.2	18.7	10	1/2	1/2
1993-1-VXL	6,000	1-1/4	1	950	2100	18.5	13.4	10	1/2	1/2

1" STRAIGHT

1992

1" STRAIGHT IMPACT WRENCH WITH 8" EXTENDED ANVIL

- Provides 1,800 ft-lb maximum torque and 2,000 ft-lb of loosening torque
- Low maintenance pin-less hammer provides ultimate reliability and added hitting power
- Features enlarged inner cavity of rotating "D" handle grip
- Combined forward/reverse and power management switch
- Triple heated Ni-Cr-Mo alloy steel hammer mechanism parts and anvil provides ultimate reliability
- Combined through hole and friction ring socket retainer



1992-1

1" STRAIGHT IMPACT WRENCH



1994

1" SUPER DUTY STRAIGHT IMPACT WRENCH WITH 8" EXTENDED ANVIL

- Provides 2,300 ft-lb maximum torque and 2,500 ft-lb of loosening torque
- Low maintenance pin-less hammer provides ultimate reliability and added hitting power
- Combined forward/reverse and power management switch
- Triple heat treated alloy steel hammer cage and anvil
- Rugged construction with reliable bolt-on assist side handle
- Hammer case can be repositioned for the side handle to be on right or left side
- Brushed aluminum motor housing
- AIRCAT's most reliable 1" Impact Wrench
- Combined through hole and friction ring socket retainer



SPECIFICATIONS

Model No.	Free Speed (RPM)	Bolt Capacity (in.)	Square Drive (in.)	Impacts Per Minute	Max. Torque (ft-lb) @90 psi	Weight (lbs.)	Length (in)	Air Cons. (CFM)	Rec. Hose Size (in.)	Air Inlet NPT (in.)
1992	5,000	1-1/4	1 x 8	1600	1800	26.0	22.0	12	1/2	1/2
1992-1	5,000	1-1/4	1	1600	1800	23.2	15.5	12	1/2	1/2
1994	4,500	1-1/4	1 x 8	1100	2300	35.0	26.0	16	1/2	1/2

RATCHETS

Our ratchet assortment has been expanded to offer impacting ratchets, long reach ratchets and sealed flat head ratchets.



RATCHETS

1/4"



807-25 **1/4" "MINI" PALM RATCHET**

- 35 ft-lb Maximum torque
- 300 RPM provides fast run-down
- Ergonomic composite over mold grip provides comfort
- Great for work around radiators and confined spaces
- Only 5.4" long and weighs only 1.1 lbs.



800 **1/4" COMPOSITE RATCHET**

- 35 ft-lb Maximum torque
- 320 RPM provides fast rundown
- Single pawl mechanism
- Superior internal mechanics
- Patented quiet tuned exhaust (82 dBA)
- Feather trigger for control - Most comfortable trigger lever in the industry!
- Ergonomically designed housing



804 **1/4" RATCHET**

- 30 ft-lb Maximum torque
- 280 RPM
- The single piece, high grade, alloy steel housing and ratchet head increase reliability and eliminates "loosening" of the ratchet head
- Uniquely designed transmission gear increases the rate of torque build-up
- Ergonomic composite over mold grip provides comfort



808-15-25 **1/4" LONG REACH RATCHET (15-INCH)**

- 30 ft-lb Maximum torque
- 200 RPM
- Exclusive AIRCAT design
- Extended drive shaft provides access for hard to reach fasteners
- High grade materials and additional support bearings provide reliability

SPECIFICATIONS

Model No.	Free Speed (RPM)	Bolt Capacity (in.)	Square Drive (in.)	Max. Torque (ft-lb) @90 psi	Weight (lbs.)	Length (in)	Air Cons. (CFM)	Rec. Hose Size (in.)	Air Inlet NPT (in.)
807-25	300	3/8	1/4	35	1.10	5.4	3	3/8	1/4
800	320	3/8	1/4	35	1.60	8.5	4	3/8	1/4
804	280	3/8	1/4	30	1.55	7.15	4	3/8	1/4
808-15-25	200	3/8	1/4	30	3.10	15.3	4	3/8	1/4

RATCHETS



807 3/8" "MINI" PALM RATCHET

- 35 ft-lb Maximum torque
- 300 RPM provides fast run-down
- Built-in quick socket release button
- Ergonomic composite over mold grip provides comfort
- Great for work around radiators and confined spaces
- Only 5.4" long and weighs only 1.1 lbs.



801 3/8" COMPOSITE RATCHET

- 35 ft-lb Maximum torque
- 320 RPM provides fast run-down
- Single pawl mechanism
- Patented quiet tuned exhaust (82 dBA)
- Feather trigger for control
- Ergonomically designed housing



810-RW 3/8" COMPACT IMPACTING RATCHET

- 50 ft-lb Maximum torque
- 550 RPM provides ultra fast run-down
- Roller clutch impact mechanism prevents kick-back
- FWD/REV Switch and safety lock prevents unwanted directional changes
- Silencing technology reduces noise level to 86 dBA)
- Only 6.3" long and weighs only 1.4 lbs.



802 3/8" COMPOSITE RATCHET

- 70 ft-lb Maximum torque
- 280 RPM
- Durable twin pawl mechanism
- Patented quiet tuned exhaust (82 dBA)
- Feather trigger for control
- Ergonomically designed housing

SPECIFICATIONS

Model No.	Free Speed (RPM)	Bolt Capacity (in.)	Square Drive (in.)	Max. Torque (ft-lb) @90 psi	Weight (lbs.)	Length (in)	Air Cons. (CFM)	Rec. Hose Size (in.)	Air Inlet NPT (in.)
807	300	3/8	3/8	35	1.1	5.4	3	3/8	1/4
801	320	3/8	3/8	35	1.6	8.5	4	3/8	1/4
810-RW	550	3/8	3/8	50	1.4	6.3	4	3/8	1/4
802	280	3/8	3/8	70	2.75	10.5	4	3/8	1/4

809-SH**3/8" SEALED FLAT HEAD RATCHET**

- 60 ft-lb Maximum torque
- 350 RPM run-down speed
- Low profile flat head allows access into confined work areas
- Sealed head design eliminates dirt and debris entering the ratchet mechanism increasing reliability
- Convenient and comfortable trigger operation
- Quick change rotational forward/reverse switch
- 360° Rotational exhaust deflector allows exhaust air to be directed as preferred

803-RW**3/8" IMPACTING RATCHET**

- 80 ft-lb Maximum torque
- 600 RPM run-down speed with built-in regulator for control
- Internal impact mechanism eliminates torque reaction and risk of finger trapping
- Very quiet compared to conventional air ratchets - only (79 dBA)
- Composite handle grip increases operating comfort
- Needle bearing construction increases reliability
- Push and lock forward/reverse switch

806**3/8" RATCHET**

- 80 ft-lb Maximum torque
- 200 RPM
- Strongest 3/8" ratchet in its class!
- Unique variable speed throttle provides unmatched control
- Enlarged ratchet head provides added reliability
- Ratchet head protective cover adds protection
- Soft touch coated handle grip increases operating comfort
- Needle bearing construction increases reliability
- 360° Rotational exhaust allows exhaust air to be directed as preferred

SPECIFICATIONS

Model No.	Free Speed (RPM)	Bolt Capacity (in.)	Square Drive (in.)	Max. Torque (ft-lb) @90 psi	Weight (lbs.)	Length (in)	Air Cons. (CFM)	Rec. Hose Size (in.)	Air Inlet NPT (in.)
809-SH	350	1/2	3/8	60	2.9	12.4	4	3/8	1/4
803-RW	600	1/2	3/8	80	2.4	10.5	4	3/8	1/4
806	200	1/2	3/8	80	2.5	10.9	4	3/8	1/4

RATCHETS



WARNING: Use with care to avoid finger trapping.

805-HT **3/8" HIGH TORQUE RATCHET**

- 130 ft-lb Maximum torque
- 180 RPM
- Latest design ratchet head eliminates "spreading"
- Reliable single pawl design
- Extra large ratchet head increases reliability
- Rapid response and variable speed trigger
- Quiet for such a powerful ratchet (84 dBA)
- Ergonomically designed contoured grip and trigger provide ultimate operating comfort



808-15 **3/8" LONG REACH RATCHET (15 INCH)**

- 30 ft-lb Maximum torque
- 200 RPM
- Exclusive AIRCAT design
- Extended drive shaft provides access for hard to reach fasteners
- High grade materials and additional support bearings provide reliability



808-22 **3/8" LONG REACH RATCHET (22 INCH)**

- 65 ft-lb Maximum torque
- 160 RPM
- Exclusive AIRCAT design
- Extended drive shaft provides access for hard to reach fasteners
- High grade materials and additional support bearings provide reliability

SPECIFICATIONS

Model No.	Free Speed (RPM)	Bolt Capacity (in.)	Square Drive (in.)	Max. Torque (ft-lb) @90 psi	Weight (lbs.)	Length (in)	Air Cons. (CFM)	Rec. Hose Size (in.)	Air Inlet NPT (in.)
805-HT	180	5/8	3/8	130	3.3	12.45	6	3/8	1/4
808-15	200	1/2	3/8	30	3.1	15.3	4	3/8	1/4
808-22	160	1/2	3/8	65	4.3	22.5	6	3/8	1/4

3/8-1/2"



802-5 **1/2" COMPOSITE RATCHET**

- 70 ft-lb Maximum torque
- 280 RPM
- Durable twin pawl mechanism
- Patented quiet tuned exhaust (82 dBA)
- Feather trigger for control
- Ergonomically designed housing
- Most comfortable trigger lever in the industry



809-SH-5 **1/2" SEALED FLAT HEAD RATCHET**

- 60 ft-lb Maximum torque
- 350 RPM provides fast rundown
- Low profile flat head allows access into confined work areas
- Sealed head design eliminates dirt and debris from entering the ratchet mechanism increasing reliability
- Convenient and comfortable trigger operation
- Quick change forward/reverse switch
- 360° Rotational exhaust deflector allows exhaust air to be directed as preferred



805-HT-5 **1/2" HIGH TORQUE RATCHET**

- 130 ft-lb Maximum torque
- 180 RPM
- Latest design ratchet head eliminates "spreading"
- Reliable single pawl design
- Extra large ratchet head increases reliability
- Rapid response and variable speed trigger
- Quiet for such a powerful ratchet (84 dBA)
- Ergonomically designed contoured grip and trigger provide ultimate operating comfort

WARNING: Use with care to avoid finger trapping.

SPECIFICATIONS

Model No.	Free Speed (RPM)	Bolt Capacity (in.)	Square Drive (in.)	Max. Torque (ft-lb) @90 psi	Weight (lbs.)	Length (in)	Air Cons. (CFM)	Rec. Hose Size (in.)	Air Inlet NPT (in.)
802-5	280	3/8	1/2	70	2.75	10.5	4	3/8	1/4
809-SH-5	350	1/2	1/2	60	2.9	12.4	4	3/8	1/4
805-HT-5	180	1/2	1/2	130	3.3	12.45	6	3/8	1/4



GRINDERS and CUT-OFF TOOLS

AIRCAT® Die Grinders and Cut-off Tools feature patented internal silencing. The most comfortably designed triggers in the industry with ergonomically designed grips.

The precision collets, spindles and gears provide low service run-out and long life.

AIRCAT® offers a selection of 16 die grinders and cut-off tools with a choice of 0.3 HP to 1.0 HP. Certain AIRCAT® models offer spindle locks and are reversible.

STRAIGHT DIE GRINDERS

6200

.4 HP MINI COMPOSITE STRAIGHT DIE GRINDER



- 20,000 RPM
- .4 HP Motor
- Patented quiet tuned exhaust (82 dBA)
- Superior steel grade internal bearings for longer life
- Feather trigger for better speed control
- Ergonomically designed housing
- Most comfortable trigger in the industry

6201

.5 HP COMPOSITE STRAIGHT DIE GRINDER



- 22,000 RPM
- .5 HP Motor
- Patented quiet tuned exhaust (82 dBA)
- Superior steel grade internal bearings for longer life
- Feather trigger for better speed control
- Ergonomically designed housing
- Most comfortable trigger in the industry

6210

.5 HP COMPOSITE EXTENDED STRAIGHT DIE GRINDER



- 22,000 RPM
- .5 HP Motor
- Patented quiet tuned exhaust (82 dBA)
- Superior steel grade internal bearings for longer life
- Feather trigger for better speed control
- Ergonomically designed housing
- Extended head to reach in tight spots
- Most comfortable trigger in the industry

SPECIFICATIONS

Model No.	Free Speed (RPM)	Motor (HP)	Collet Size (in)	Gears	Exhaust	Weight (lbs.)	Length (in)	Air Cons. (CFM)	Rec. Hose Size (in.)	Air Inlet NPT (in.)
6200	20,000	.4	1/4	Direct Drive	Rear	.9	6.5	4	3/8	1/4
6201	22,000	.5	1/4	Direct Drive	Rear	1.1	8.5	4.2	3/8	1/4
6210	22,000	.5	1/4	Direct Drive	Rear	2.5	13.5	4.2	3/8	1/4

STRAIGHT DIE GRINDERS



6285

.75 HP STRAIGHT DIE GRINDER WITH SPINDLE LOCK

- 20,000 RPM
- .75 HP Non stall motor
- Spindle lock feature for easy accessory change
- Speed control switch located on top of the grip for added control
- Erickson® style precision collet
- Over-mold composite handle and grip for comfort
- Low noise only (79 dBA)
- Low vibration only 2.5 m/sec²



6290

.75 HP REVERSIBLE STRAIGHT DIE GRINDER

- 20,000 RPM
- .75 HP Non stall motor
- Speed control switch located under the trigger for added control
- Forward/Reverse switch located on top of the grip for easy directional changes
- Erickson® style precision collet
- Over-mold composite handle and grip for comfort
- Low noise only (79 dBA)
- Low vibration only 2.5 m/sec



6260

1.0 HP COMPOSITE STRAIGHT DIE GRINDER

- 22,000 RPM
- Full 1.0 HP non-stall motor
- Patented quiet tuned exhaust (82 dBA)
- Superior steel grade internal bearings for longer life
- Feather trigger for better speed control
- Ergonomically designed housing
- Most comfortable trigger in the industry

SPECIFICATIONS

Model No.	Free Speed (RPM)	Motor (HP)	Collet Size (in)	Gears	Exhaust	Weight (lbs.)	Length (in)	Air Cons. (CFM)	Rec. Hose Size (in.)	Air Inlet NPT (in.)
6285	20,000	0.75	1/4	Direct drive	Rear	1.4	7	4.1	3/8	1/4
6290	20,000	0.75	1/4	Direct Drive	Rear	1.4	7	4.1	3/8	1/4
6260	22,000	1.0	1/4	Direct Drive	Rear	1.2	9.25	6.0	3/8	1/4

STRAIGHT / ANGLE DIE GRINDERS

6270

1.0 HP COMPOSITE EXTENDED STRAIGHT DIE GRINDER



- 20,000 RPM
- 1.0 HP Non stall motor
- Patented "Silencing Technology" reduces noise to (80 dBA)
- 6" Extension to reach tight areas
- Ergonomically designed housing
- Most comfortable trigger in the industry

6255

.4 HP COMPOSITE ANGLE DIE GRINDER



- 18,000 RPM
- .4 HP Motor
- Superior steel grade internal bevel gears for longer life
- Feather trigger for better speed control
- Patented quiet technology (82 dBA)
- Excellent for high speed blending, smoothing, porting and deburring in confined areas
- Ergonomically designed housing
- Most comfortable trigger in the industry

6280

.75 HP ANGLE DIE GRINDER WITH SPINDLE LOCK



- 18,000 RPM
- .75 HP non stall motor
- Spindle lock feature for easy accessory change
- Speed control switch located at the top of the grip for added control
- Erickson® style precision collet
- Composite handle and grip for comfort
- Low noise only (79 dBA)

SPECIFICATIONS

Model No.	Free Speed (RPM)	Motor (HP)	Collet / Spindle Size (in)	Gears	Exhaust	Weight (lbs.)	Length (in)	Air Cons. (CFM)	Rec. Hose Size (in.)	Air Inlet NPT (in.)
6270	20,000	1.0	1/4	Direct Drive	Rear	3.1	14.15	6	3/8	1/4
6255	20,000	.4	1/4	Spiral-Bevel	Rear	1.1	7.0	4.2	3/8	1/4
6280	18,000	.75	1/4	5:1 Bevel Gears	Rear	1.8	7.0	4.1	3/8	1/4

DIE/ANGLE GRINDERS



6265

1.0 HP COMPOSITE ANGLE DIE GRINDER

- 18,000 RPM
- 1 HP Non stall motor
- Patented "Silencing technology" reduces noise to (89 dBA)
- Ergonomically designed housing
- Most comfortable trigger in the industry
- Feathered trigger for better speed control
- Precision bevel gears for reliability
- Includes 1 pc each 2" & 3" Roloc® style backing pads



*Accepts Type 27 & 28 wheels

6340-A

1.0 HP 4-1/2" ANGLE GRINDER WITH SPINDLE LOCK

- 11,000 RPM
- 1 HP Motor eliminates "stall" and increases reliability
- Spindle lock for easy wheel change
- Speed control switch located at the top of the grip for added control
- Multi positional rotational guard improves access
- The composite grip and throttle trigger have been ergonomically designed to provide unmatched comfort for the user
- 360° Rotational exhaust



6380

2.3 HP 5" HEAVY DUTY ANGLE GRINDER

- 12,000 RPM
- 2.3 HP Governed motor provides constant speed and unstoppable stall-less operation
- Spindle lock for easy wheel change
- Ergonomically designed composite grip
- Vibration damped side handle and throttle trigger provide unmatched comfort to the user
- Rear exhaust

SPECIFICATIONS

Model No.	Free Speed (RPM)	Motor (HP)	Spindle / Collet Size	Wheel Size (in.)	Gears	Exhaust	Weight (lbs.)	Length (in.)	Air Cons. (CFM)	Rec. Hose Size (in.)	Air Inlet NPT (in.)
6265	18,000	1.0	1/4"	Max 3	Spiral Bevel	Rear	1.8	9.5	4.2	3/8	1/4
6340-A	11,000	1.0	5/8" - 11	4-1/2	Spiral Bevel	Rear	2.25	8.75	6	3/8	1/4
6380	12,000	2.3	5/8" - 11	5	Spiral Bevel	Rear	3.97	9.15	10	1/2	3/8

CUT-OFF TOOLS



6505

.5 HP 3" COMPOSITE CUT-OFF TOOL

- 20,000 RPM Free speed
- .5 HP Motor
- Patented quiet tuned exhaust (86 dBA)
- Feather trigger for better speed control
- Ergonomically designed housing
- Compact and low weight
- Most comfortable trigger in the industry



6520

.5 HP 3" REVERSIBLE CUT-OFF TOOL

- 18,000 RPM Free speed
- .5 HP Motor
- Wheel directional change on top of grip allows operator to change the direction of sparks
- Speed control switch located under the trigger for added control
- Cuts 3/8" rolled steel or 18 gauge steel sheet
- Impact resistant, composite housing
- Extra heavy duty dual spindle bearings for added reliability
- Patented muffler design reduces noise level to (88 dBA)



6530

.5 HP 3" FLEX HEAD CUT-OFF TOOL

- 18,000 RPM Free Speed
- .5 HP Motor
- 3 Position Flex Head
- Cuts 3/8" rolled steel or 18 gauge steel sheet
- 360° Rotational guard and exhaust
- Patented muffler design reduces noise level to (90 dBA)

3 Position Flex Head

SPECIFICATIONS

Model No.	Free Speed (RPM)	Motor (HP)	Wheel Size (in)	Gears	Cutting Capacity	Exhaust	Weight (lbs.)	Length (in)	Air Cons. (CFM)	Rec. Hose Size (in.)	Air Inlet NPT (in.)
6505	20,000	.5	3	Direct Drive	3/4" Rolled Steel / 18 Gauge	Rear	1.75	9.0	4.2	3/8	1/4
6520	18,000	.5	3	Single reduction	3/4" Rolled Steel / 18 Gauge	Rear	1.8	9.5	6	3/8	1/4
6530	18,000	.5	3	Direct Drive	3/4" Rolled Steel / 18 Gauge	Rear	2.6	8.8	6	3/8	1/4

CUT-OFF TOOLS



6525-A

.6 HP 3" IN-LINE CUT-OFF TOOL

- 1,800 RPM
- .6 HP Motor provides non-stall operation
- Side mounted wheel and in-line motor allows for straight cutting of materials
- Composite grip has been ergonomically designed to provide unmatched comfort for the user
- Rear exhaust allows exhaust air to be directed away from the user
- Manufactured from high grade material precision parts designed for industrial and heavy duty automotive use



6560

1 HP 4" COMPOSITE CUT-OFF TOOL

- 14,000 RPM
- 1 HP non stall motor
- Patented "Silencing technology" reduces noise to [89 dBA]
- Composite grip and throttle trigger for comfort
- Cuts 3/8" Rolled Steel/18 Gauge
- Features 4" diameter wheel

6275-A

1.0 HP 4" INSIDE CUT-OFF TOOL WITH SPINDLE LOCK



- 14,000 RPM
- 1.0 HP motor eliminates "stall" and increases reliability
- Extended length for better reach. Get in where other tools fail to go!
- Compact tapered gear housing with close-coupled grinding wheel
- Reaches inside corners of as little as 30° with 4" wheel
- Superior steel grade internal gears for longer life
- Spindle lock for easy wheel change
- 11 position rotational guard
- Grinder disc sizes: 4" (1/16 x 3/8) (1/8 x 3/8)

SPECIFICATIONS

Model No.	Free Speed (RPM)	Motor (HP)	Wheel Size (in)	Gears	Cutting Capacity	Exhaust	Weight (lbs.)	Length (in)	Air Cons. (CFM)	Rec. Hose Size (in.)	Air Inlet NPT (in.)
6525-A	18,000	0.6	3	Direct Drive	3/8" Rolled Steel / 18 Gauge	Rear	2.2	7.95	6	3/8	1/4
6560	14,000	1.0	4	Single reduction	3/4" Rolled Steel / 18 Gauge	Rear	1.8	9.5	4.2	3/8	1/4
6575-A	14,000	1.0	4	Direct Drive	3/4" Rolled Steel / 18 Gauge	Rear	3.75	15.5	6	3/8	1/4

DRILLS, HAMMERS, POLISHERS, TIRE BUFFERS, SAW and NIBBLER

AIRCAT's latest designs and innovations add reliability and reduced noise levels and weight, while providing added operator comfort.

AIRCAT drills feature precision, fully caged planetary gears, and trigger mounted reverse switches for instant change of direction. The AIRCAT ergonomic grip designs provide perfect balance and added operator comfort.

AIRCAT hammers feature a multi-patented silencing system and internal vibration damping that reduce vibration levels to 4.2 m/sec^2 . The AIRCAT ergonomic grip featured in the hammers provide perfect balance and added operator comfort.



DRILLS



4338 **.6 HP 3/8" COMPOSITE REVERSIBLE DRILL**

- 1,800 RPM
- .6 HP Motor
- Fitted with Jacobs® keyless chuck
- Feather trigger for better speed control
- Trigger mounted reverse for instant change of direction
- Superior grade steel planetary gear for longer life
- Patented quiet tuned exhaust (85 dBA)
- Patented ergonomically designed handle



4450 **.6 HP 1/2" COMPOSITE REVERSIBLE DRILL**

- 400 RPM
- .6 HP Motor
- Fitted with keyed chuck
- Feather trigger for better speed control
- Trigger mounted reverse for instant change of direction
- Superior grade steel planetary gear for longer life
- Patented quiet tuned exhaust (85 dBA)
- Patented ergonomically designed handle

SPECIFICATIONS

Model No.	Free Speed (RPM)	Motor (HP)	Chuck Size (in.)	Gears	Spindle Thread Size (in.)	Weight (lbs.)	Length (in)	Air Cons. (CFM)	Rec. Hose Size (in.)	Air Inlet NPT (in.)
4338	1,800	.6	3/8	Planetary	3/8 x 24	2.5	7.0	6	3/8	1/4
4450	400	.6	1/2	Planetary	3/8 x 24	3.0	8.0	6	3/8	1/4

3/8-1/2"



4439

.7 HP 3/8" COMPOSITE REVERSIBLE DRILL

- 2,400 RPM
- .7 HP motor
- Low weight composite housing reduces weight
- Patented one-click reverse button provides instant change of direction
- Patented "silencing technology" reduces the noise level to (83 dBA)
- Patented grip has been ergonomically designed to perfectly fit the hand-providing unmatched comfort for the user
- Forward position handle allows more drilling control to start hole and more control to maintain the drilled hole axis and allows operator to apply increased force
- Fitted with keyed chuck



4451

.7 HP 1/2" COMPOSITE REVERSIBLE DRILL

- 400 RPM
- 0.7 HP motor
- Low weight composite housing reduces weight.
- Patented one-click reverse button provides instant change of direction
- Patented "silencing technology" reduces the noise level to (83 dBA)
- Patented grip has been ergonomically designed to perfectly fit the hand-providing unmatched comfort for the user
- Forward position handle allows more drilling control to start hole and more control to maintain the drilled hole axis and allows operator to apply increased force
- Fitted with keyed chuck



4337

.75 HP 3/8" ANGLE DRILL

- 1,600 RPM
- .75 HP motor
- Precision spiral bevel gears increase reliability
- Conveniently positioned forward/reverse knob
- Built-in speed regulator for added control
- Ergonomically designed composite over-mold grip and throttle lever provide unmatched comfort for the user
- Fitted with grease nipple for gear lubrication
- Internal silencing reduces noise level to (75 dBA)
- Rear exhaust directs air away from work area
- Fitted with keyed chuck

SPECIFICATIONS

Model No.	Free Speed (RPM)	Motor	Spindle Thread Size (in.)	Chuck Size (in)	Gears	Weight (lbs.)	Length (in)	Air Cons. (CFM)	Rec. Hose Size (in.)	Air Inlet NPT (in.)
4439	2,400	0.7	3/8 x 24	3/8	Caged Planetary	3.17	7.4	9	3/8	1/4
4451	400	0.7	3/8 x 24	1/2	Caged Planetary	4.12	9.27	9	3/8	1/4
4337	1,600	0.75	3/8 x 24	3/8	Spiral Bevel	2.4	8.3	6	3/8	1/4

HAMMERS



- Model 5100-A Includes: Blow Mold Kit, 5 Pc. Chisel Set and Quick Change Retainer

5100-A-T

.401 SHANK COMPOSITE MEDIUM STROKE AIR HAMMER (TOOL ONLY)

5100-A

.401 SHANK COMPOSITE MEDIUM STROKE AIR HAMMER KIT

- 3,000 Blows per minute for fast cutting action
- High performance and low weight
- Multi-patented muffler/exhaust system gives this tool and extremely low noise level of (88 dBA) and vibration level of 4.2 m/sec²
- 5100-A-T and 5100-A includes heavy duty ball-lock quick change chisel retainer adding safety and reliability



5200-A-T

.401 SHANK COMPOSITE LONG STROKE AIR HAMMER

- 2,100 Blows per minute provide hard hitting cutting action
- 3-3/4" Piston stroke
- Vibration damped technology reduces the vibration level to 4.2 m/sec²
- Patented AIRCAT design double injection composite grip has been ergonomically designed to provide unmatched comfort for the user
- Patented AIRCAT silencing technology
- Includes heavy duty ball-lock quick change chisel retainer adding safety and reliability



- Model 5300-A Includes: Quick Change Chisel Retainer and 4 Pc. Chisel Set

5300-A-T

.498 SHANK SUPER DUTY AIR HAMMER (TOOL ONLY)

5300-A

.498 SHANK SUPER DUTY AIR HAMMER KIT

- 1,760 Blows per minute
- 0.498" Shank opening
- Includes heavy duty "Quick Change Chisel Retainer"
- Patented ergonomically designed grip provides unmatched comfort for the user
- Designed for heavy duty applications such as driving out shackles, kingpins, and also used for cutting large bolts, nuts and fasteners

SPECIFICATIONS

Model No.	Free Speed (BPM)	Piston Stroke	Shank Opening	Retainer	Valve	Weight (lbs.)	Length (in)	Air Cons. (CFM)	Rec. Hose Size (in.)	Air Inlet NPT (in.)
5100-A-T	3,000	2-5/8	.401"	Safety-lock	Plate	3.3	7.6	6	3/8	1/4
5200-A-T	2,100	3-3/4	.401"	Safety-lock	Plate	4.4	11.0	6	3/8	1/4
5300-A-T	1,760	2-11/16	.498"	Quick Change	Plate	4.6	8.95	6	3/8	1/4

SPECIALTY TOOLS



6330 **18 GAUGE NIBBLER**

- 2,500 stroke/minute motor provides fast cutting action in steel up to 18 gauge
- The 6350 has the smallest cut radius of any nibbler at only 3/16" allowing clean cuts in tight corners
- The "over sized" anvil and punch dramatically increase reliability of these high wear parts
- Includes an additional punch
- Composite handle and throttle lever design provide comfortable and convenient operation
- The rotational 360° rear exhaust muffler allows exhaust air to be directed as preferred
- Precision engineered components make this tool suitable for high volume



6350 **LOW VIBRATION AIR SAW**

- 9,500 stroke/minute motor provides fast cutting action
- The internal damping system reduces the vibration level to 2.5m/sec²
- Comes complete with 18, 24 and 32 teeth power saw blades
- The metal blade retainer increases reliability
- The rotational 360° rear exhaust muffler allows exhaust air to be directed as preferred
- Features a short overall length of only 8" and low a weight of only 1.13 lbs. providing good work area access and comfortable operation



6390 **COMPACT NEEDLE SCALER**

- 4,800 BPM
- 1-1/4" Stroke
- Low weight compact design
- Durable steel housing
- Best for removal of rust, paint and scale on flat or irregular surfaces

SPECIFICATIONS

Model No.	Free Speed (BPM/Strokes)	Cutting Capacity	Exhaust	Weight (lbs.)	Length (in)	Air Cons. (CFM)	Rec. Hose Size (in.)	Air Inlet NPT (in.)
6330	2,500	8 Gauge	Rear	2.25	7.0	3.5	3/8	1/4
6350	9,500	3/16" Steel Plate - 18 Gauge	Rear	1.13	8.0	4	3/8	1/4
6390	4,800	N/A	Rear	2.90	11.50	4	3/8	1/4

SPECIALTY TOOLS

6402 .6 HP 2,600 RPM COMPOSITE TIRE BUFFER

6403 .6 HP 3,600 RPM COMPOSITE TIRE BUFFER



- 2,600 and 3,600 RPM
- Stall resistant 0.60 HP motor
- Convenient and comfortable throttle lever design
- Ergonomic molded handle grip adds comfort and insulation in cold weather
- Complete with coaxial rear hose assembly to eliminate blowing of rubber particles/dust in the work area
- Low noise level
- Low air consumption
- 5/16" Hex quick change chuck with threaded arbor for mounting buffing cones and accessories
- Model 6403 is designed for tire re-capping and tire buffing

6400

COMPOSITE HIGH SPEED TIRE BUFFER/DRILL



- 22,000 RPM
- Stall resistant 0.75 HP motor
- Built-in regulator for added control on the job
- Convenient and comfortable throttle lever design
- Ergonomic molded handle grip adds comfort and insulation in cold weather
- Complete with coaxial rear hose assembly to eliminate blowing of rubber particles/dust in the work area
- Short overall tool length of only 8" improves access in work area
- Low noise level
- Low air consumption
- 3/8" Precision keyed chuck
- Spindle thread 5/16" x 24

SPECIFICATIONS

Model No.	Free Speed (RPM)	Chuck Size (in.)	Spindle Thread Size (in.)	Weight (lbs.)	Length (in)	Air Cons. (CFM)	Rec. Hose Size (in.)	Air Inlet NPT (in.)
6402	2,600	5/16" Internal Hex	N/A	1.75	9.0	3.5	3/8	1/4
6403	3,600	5/16" Internal Hex	N/A	1.75	9.0	3.5	3/8	1/4
6400	22,000	3/8	3/8 x 24	1.66	8.0	4.1	3/8	1/4

SANDERS & POLISHERS

AIRCAT sanders feature a patented motor design that reduces vibration to 1.8 m/sec². These motors are double sealed to eliminate any dust contamination of internal parts. AIRCAT sanders are the first sanders with technology that allows the tools to be used lubrication free, eliminating any oil mist contamination of the work surface. To further extend the life and reliability of the tools they also incorporate a double bearing design. AIRCAT sanders are built using the latest technology composite grips and handles proving lower weight and added comfort for the operator. The selection of AIRCAT sanders are designed to meet the latest market requirements for ultra fine paint finishing and spot repair work.



SANDERS

6700 SERIES Low Vibration "Lube-Free" Orbital and Geared Sanders

AIRCAT has developed a series of "lubrication free" sanders that incorporate the latest engineering concepts, advanced materials and patented designs. The AIRCAT technology reduces weight, noise and vibration, while extending the tool life. The AIRCAT "smooth design throttle lever" and the "ergonomic grip" featured in orbital sanders provide unmatched operating comfort.

- A choice of eighteen (18) models 3/32" and 3/16" orbit options
- Non vacuum, central vacuum and self vacuum options
- 1", 3", 5" 6", and 8" "hook & loop" and PSA pad options
- Only 1.6 CFM average air consumption and 6.2 CFM continuous running under load
- Advanced silencing technology reduces noise levels to (75-78 dBA)
- Patented double sealed, lubrication free motor prevents dust contamination of the air motor and eliminates the need for oiling
- Orbital sanders feature the AIRCAT "smooth design" throttle lever and "ergonomic grip" providing unmatched comfort
- Patented "anti vibration" motor reduces vibration level to 1.8 m/sec²
- Low weight: Orbital sanders 2.0 lbs. and geared sanders 3.4 lbs.
- Low profile: Orbital sanders height 4.3" and geared sanders height 4.5"



6700-1-332



6700-3-336-PSA
6700-3-336
6700-3-336CV

Model No.	Description	Pad Size (in)	Pad Thread (in)	Orbit (in)	Pad Type	Pad Holes	Free Speed (RPM)
6700-1-332	Non Vac Nib Palm Sander	1	5/16 x 24	3/32	Hook & Loop	NA	8,000
6700-3-336 / 6700-3-336-PSA	Non Vac Orbital Palm Sander/Polisher	3	5/16 x 24	3/16	Hook & Loop / PSA	NA	11,000
6700-3-336CV	Central Vac Orbital Palm Sander/Polisher	3	5/16 x 24	3/16	Hook & Loop	6	11,000
6700-5-336	Non Vac Orbital Palm Sander	5	5/16 x 24	3/16	Hook & Loop	NA	11,000
6700-5-336CV	Central Vac Orbital Palm Sander	5	5/16 x 24	3/16	Hook & Loop	6	11,000
6700-6-332 / 6700-6-332-PSA	Non Vac Orbital Palm Sander	6	5/16 x 24	3/32	Hook & Loop / PSA	NA	11,000
6700-6-332CV	Central Vac Orbital Palm Sander	6	5/16 x 24	3/32	Hook & Loop	6	11,000
6700-6-332SV	Self Vac Orbital Palm Sander	6	5/16 x 24	3/32	Hook & Loop	6	11,000
6700-6-336 / 6700-6-336-PSA	Non Vac Orbital Palm Sander	6	5/16 x 24	3/16	Hook & Loop / PSA	NA	11,000
6700-6-336CV	Central Vac Orbital Palm Sander	6	5/16 x 24	3/16	Hook & Loop	6	11,000
6700-6-336SV	Self Vac Orbital Palm Sander	6	5/16 x 24	3/16	Hook & Loop	6	11,000
6700-6G	Non Vac Geared Planetary Motion Sander	6	5/16 x 24	3/16	Hook & Loop	NA	900
6700-6GCV	Central Vac Geared Planetary Motion Sander	6	5/16 x 24	3/16	Hook & Loop	6	900
6700-8G	Non Vac Geared Planetary Motion Sander	8	5/16 x 24	3/16	Hook & Loop	NA	900
6700-8GCV	Central Vac Geared Planetary Motion Sander	8	5/16 x 24	3/16	Hook & Loop	8	900

ORBITAL & GEARED SANDERS



6700-5-336
6700-6-336-PSA
6700-6-336



6700-5-336CV
6700-6-336CV



6700-6-332
6700-6-332-PSA
6700-6-332CV

6700-6-336SV
6700-6-332SV



6700-8G
6700-8GCV



6700-6G
6700-6GCV

Weight (lbs)	Length w/Pad Fitted (in)	Width w/Pad Fitted (in)	Height w/Pad Fitted (in)	Noise Level d(B)A	Vibration m/sec ²	Average Air Cons. (CFM)	Air Inlet NPT (in.)
1.7	6.7	3.0	4.3	75	1.8	1.6	1/4
1.8	5.5	3.0	4.3	75	1.8	1.6	1/4
1.8	7.2	3.0	4.3	75	1.8	1.6	1/4
2.0	6.7	5.0	4.3	75	1.8	1.6	1/4
2.0	8.4	5.0	4.3	75	1.8	1.6	1/4
2.0	6.8	6.0	4.3	75	1.8	1.6	1/4
2.0	8.4	6.0	4.3	75	1.8	1.6	1/4
2.0	8.1	6.0	4.3	75	1.8	1.6	1/4
2.0	6.8	6.0	4.3	75	1.8	1.6	1/4
2.0	8.4	6.0	4.3	75	1.8	1.6	1/4
2.0	8.1	6.0	4.3	75	1.8	1.6	1/4
3.4	10.2	6.0	4.5	78	2.5	3.0	1/4
3.4	11.0	6.0	4.5	78	2.5	3.0	1/4
3.5	11.2	8.0	4.5	78	2.5	3.0	1/4
3.5	12.0	8.0	4.5	78	2.5	3.0	1/4

SANDERS

6700-JBS-332 **JITTERBUG SANDER**



- 10,000 RPM
- 3/32" Orbit
- 7.75 x 2.75 Rectangle hook and loop pad
- Advanced silencing technology reduces noise level to (80 dBA)
- Patented doubled sealed, lubrication-free motor prevents dust contamination and eliminates the need to oil the tool
- Patented "anti-vibration" motor reduces vibration level to 1.8 m/sec²

6525-ABS **18" BELT SANDER** **(1/4" & 1/2" Contact Arm Included)**



- 20,000 RPM
- 0.6 HP Motor provides non-stall operation
- 360° Rotational guard and belt
- Side assist handle provides added control and reduces fatigue
- Ergonomically designed composite grip provides unmatched comfort
- Rear exhaust directs air away from user
- Manufactured from high grade material and precision parts designed for industrial and heavy duty automotive use

The following additional contact arms are readily available

Part No.	Description	Part No.	Description
96V6201	1/8" x 18"	96U6201	3/4" x 18"
96X6201	1/4" x 18"	96S6201	1" x 18"
96W6201	1/2" x 18"		

SPECIFICATIONS

Model No.	Free Speed (RPM)	Pad /Belt Size (in.)	Exhaust	Weight (lbs.)	Length (in)	Air Cons. (CFM)	Rec. Hose Size (in.)	Air Inlet NPT (in.)
6700-JBS-332	10,000	7.75 x 2.75	Rear	2.5	7.75	9	3/8	1/4
6525-ABS	20,000	1/4 x 18	Rear	2.6	15.4	6	3/8	1/4

SANDERS / POLISHERS



6310

6" COMPOSITE DUAL ACTION SANDER (PSA)

- 10,000 RPM
- 3/16" Orbit
- Low weight (2.3 lbs) and low air consumption (2.5 CFM average)
- Lubrication free air motor with patented double sealing to prevent dust contamination
- Isolated motor design reduces vibration to 1.8 m/sec²
- Internal silencing system reduces noise level to (82 dBA)
- Built-in thumb operated speed regulator for instant control
- Rubberized comfort palm grip
- Low profile only 3-3/4" in height



6320

SPOT SANDER/POLISHER

- 13,000 RPM
- Features internal 1/8" orbital head for ultra-fine sanding and polishing
- The combined spindle-counter balance provides reliability and reduces vibration levels to 1.8 m/sec²
- Precision alloy steel spiral-bevel gears extend tool life
- The internal silencing system reduces noise levels to (78 dBA)
- Supplied complete with hook and loop 1.25" round, 2" round, and triangular pad
- Sanding discs available in 120/180/320/600/1000/1500 grit sizes
- Lambswool and sponge polishing bonnets/pads are also available separately



6370

.6 HP COMPOSITE LOW WEIGHT VERTICAL POLISHER

- 3,500 RPM
- .6 HP Motor
- Low weight only 2.5 lbs.
- Low air consumption only 12.0 CFM
- Incorporates internal spindle thread for fitting of upholstery cleaning brushes
- Comes complete with 7" lambswool polishing bonnet
- The composite housing and handles are ergonomically designed to provide unmatched comfort for the user

SPECIFICATIONS

Model No.	Free Speed (RPM)	Pad / Bonnet Size (in.)	Spindle Thread (in.)	Exhaust	Orbit (in.)	Weight (lbs.)	Length (in)	Air Cons. (CFM)	Rec. Hose Size (in.)	Air Inlet NPT (in.)
6310	10,000	6	5/16 - 24	Rear	3/16	2.25	10.5	2.5	3/8	1/4
6320	13,000	1-1/4, 2, Triangle	1/4	Rear	1/8	1.1	6.1	2.5	3/8	1/4
6370	3,500	7	5/8" - 11	Side Handle	N/A	2.5	6.75	12.0	3/8	1/4

DCE ELECTRIC SANDERS/POLISHERS

Ideal for for mobile body repair technicians, boat builders/repairers and furniture/wood product manufacturing processes.

6700-DCE SERIES ELECTRIC PALM SANDER / POLISHER

- **FLEXIBLE:** Features a three speed “push button” setting of 10,000, 7,000, and 4,000 RPM . Allows for sanding, compounding and polishing.
- **VERY QUIET:** [70 dBA] noise level.
- **COMFORTABLE:** 0.5m/sec² vibration level.
- **CLEAN:** No exhaust air, no air borne oil, no blowing of dust and particles.
- **SAFE:** The DC current renders the tool shock hazard free and totally safe to use, the 20’ low voltage DC cable allows use around vehicles and in industrial fabrication and assembly areas.
- **EASE OF INSTALLATION:** Hook-up and installation is easy and flexible to relocate to any location where there is an AC power point; simply plug the DC converter cable into your power supply to get started.
- **INCREASED PRODUCTIVITY:** Air sanders only maintain 60% of their speed under load, while the AIRCAT DC electric sander maintains 85% of its speed under load.
- **ENERGY EFFICIENT:** 80% energy savings compared to running a compressor to power an air sander.
- **COMPLETE PACKAGE:** Comes with hook and loop backing pad, a 4-ply 100% twisted wool polishing bonnet, and a foam polishing/ compounding pad.
- Central vacuum versions available.



6700-DCE-3
6700-DCE-3V



6700-DCE-5
6700-DCE-5V
6700-DCE-6
6700-DCE-6V

SPECIFICATIONS

Model No.	Speed Settings (RPM)	Spindle Thread (in)	Pad Size (in)	Orbit (in)	Weight (lbs.)	Length (in)	Noise Level	Vibration Level	Cable Length (ft)
6700-DCE-3 6700-DCE-3V (Vac)	10,000 - 7,000 - 4,000	5/16 x 24	3	3/16	1.98	8.9	70 dBA	0.5 m/sec ²	20
6700-DCE-5 6700-DCE-5V (Vac)	10,000 - 7,000 - 4,000	5/16 x 24	5	3/16	1.98	8.9	70 dBA	0.5 m/sec ²	20
6700-DCE-6 6700-DCE-6V (Vac)	10,000 - 7,000 - 4,000	5/16 x 24	6	3/16	1.98	7.0	70 dBA	0.5 m/sec ²	20

MECHANICS CREEPER

800-C

45" ADJUSTABLE MECHANICS CREEPER WITH LIGHT



- Adjustable headrest
- Built-in LED inspection light
- Padded cushion for comfort
- Steel frame fabrication
- 3" Heavy duty casters
- Oil, grease and dirt resistant

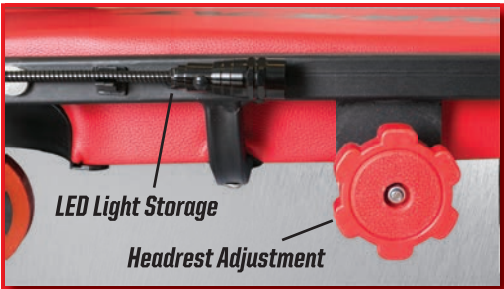

SPECIFICATIONS

Model No.	Height	Dimensions	Max Load
800-C	6.5"	45" x 23" x 6.5"	400 lbs.

ACCESSORIES



Male & Female Safety Couplers

600-C-25M
600-C-375M

1/4" NPT Male Coupler with Male & Female Fittings
3/8" NPT Male Coupler with Male & Female Fittings



600-C-25F
600-C-375F

1/4" NPT Female Coupler with Male & Female Fittings
3/8" NPT Female Coupler with Male & Female Fittings



300-C

AIRCAT® Magnetic Mat

- Easy clean vinyl casing will not damage vehicle panels
- Contains 27 magnets and holds up to 15 lbs.



500-C

AIRCAT® Tool Bag

IMPACT BOOTS



1057-THBB
Black AIRCAT® Boot
Fits Models: 1077-TH and 1057-TH



1056-XLBB
Black AIRCAT® Boot
Fits Models: 1076-XL and 1056-XL



1058-VXLBB
AIRCAT® VIBROTHERM DRIVE® Boot
Fits Models: 1059-VXL and 1058-VXL



1300-THBB
Black AIRCAT® Boot
Fits Models: 1300-TH and 1300-TH-A



1355-XLBR
Red Flame NITROCAT® Boot
Fits Models: 1375-XL and 1355-XL



1150-BB
Black AIRCAT® Boot
Fits Models: 1150, 1000, 1000-TH and 1000-TH-2



1200-KBR
Red Flame NITROCAT® Boot
Fits Model: 1200-K



1250-KBB
Black AIRCAT® Boot
Fits Model: 1250-K



1178-VXLBB
AIRCAT® VIBROTHERM DRIVE® Boot
Fits Model: 1178-VXL



1770-XLBB
Black AIRCAT® Boot
Fits Models: 1770-XL



1600-THBB
Black AIRCAT® Boot
Fits Models: 1600-TH, 1600-TH-A
and 1600-TH-A1



1778-VXLBB
AIRCAT® VIBROTHERM DRIVE® Boot
Fits Model: 1778-VXL

TECHNICAL INFORMATION

Air Supply

Tools of this class operate on a wide range of air pressure. It is recommended that air pressure of these tools measures 90 PSI at the tool while running free. Higher pressure and unclean air will shorten the tool's life because of faster wear and may create a hazardous condition and void the warranty. Water in the air line will cause damage to the tool. Drain the air tank daily. Clean the air inlet filter screen on at least a weekly schedule.

The recommended hookup procedure can be viewed in the illustration below. The air inlet used for connecting air supply has standard 1/4" NPT for smaller tools and 3/8" NPT for larger tools as specified in the tool manual. Line pressure should be increased to compensate for unusually long air hoses (over 25 feet). Minimum hose diameter should be 3/8" I.D. for smaller tools and 1/2" for larger tools as specified in the tool manual.

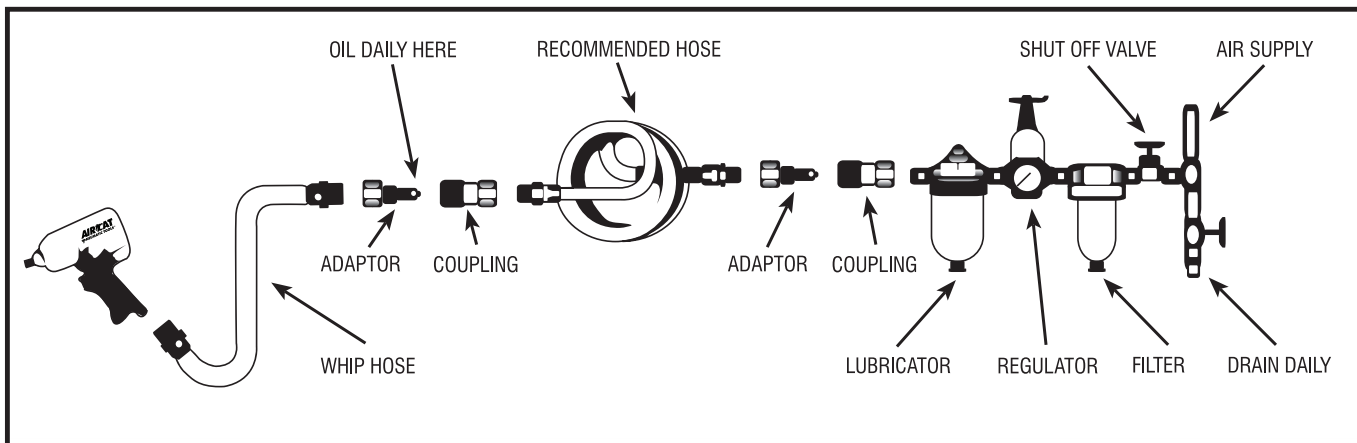

Use of Accessories with Air Tools

When selecting the correct accessory to use with your air tool(s) the following points must be carefully checked:

- The accessory is rated to run at or above the maximum rated speed of the air tool that you plan to use it on.
- Air tool Manufacturers specify these speeds in their catalogs and operator instructions.
- Accessories used on abrasive tools, impact wrenches, nut runners, ratchets, air hammers and scaling hammers must be rated for use with the relevant air tool.
- Any accessory used should be of the correct size and design for the air tool(s) that you plan to use it with.
- Worn accessories should not be used and accessories should not be modified in any way.
- Mounting and fitting instruction for any accessory to be used on an air tool must be carefully followed at all times.
- Use of worn or incorrect accessories may reduce tool performance, create excessive tool wear and can be hazardous
- Always disconnect the tool from the air supply when changing of fitting accessories, guards or other fittings.

Operator Training for Air Tool; Air Tool Accessory and Compressed Air Use

- All operators should be trained in the correct installation and use of the air tool/s that they are required to operate.
- All operators should be trained to understand the safety instructions provided by the air tool manufacturer, for each
- Air tool that they are required to operate.
- All operators should be trained in the safe use of compressed air and the use of associated air hoses, connectors and air tool accessories.
- All operators should be trained to operate an air tool and accessories safely and correctly on the application that you plan to use them for.
- Operators or service personnel should be trained to ensure that the air installation, lubricators, filters, regulators, hoses and air nipples and connectors are checked regularly to ensure that they meet the requirements set on a continuous basis.

How To Maximize Your Tools Performance And Working Life.

Compressed air is a misunderstood power source as unlike electricity that is constant and maintains constant horsepower, as compressed air drives a motor horsepower can vary dependent on how the tool is set up. The tips below will ensure that you maximize the horse power of the air motor and torque level of your impact wrench:

Air tool manufactures measure the impact wrench rated torque levels stated in there catalogs and rated horse power and RPM of the air tools stated in their catalogs based on 90 PSI are pressure entering the tool at the tool air inlet.

If the air pressure is set at the compressor or at an in-line pressure regulator at 90 PSI by the time that the air reaches the tools air inlet; the pressure will have dropped. Typically each 25' between the air pressure gauge and the tool with cause a 15% air pressure drop at the tool. In addition any restriction added to a hose hook-up, like a connector that reduces the inside diameter of the air connection will cause a severe pressure drop at the tool. Then any air leak at a connection point between the compressor and the tool will reduce air pressure. Use of the wrong air hose ID size will typically reduce tool performance by 40%-50%. Use of very small compressors to run air tools will dramatically reduce performance.

Tips To Maximize Tool Performance:

- Always use the air hose ID size recommended by the tool manufacturer.
- For any impact wrench up to 1/2" drive and other air tools always use a 3/8" ID air hose.
- For any impact wrench 3/4" and 1" drive always use a 1/2" ID air hose.
- Reduce the hose length to the shortest length practical for use, as a guide if a 25" air hose is used the pressure at the in-line regulator should be set at 105-110 PSI this will deliver 90 PSI to the tool
- Ensure that thread tape is used on all connections from the compressor to the tool
- Do not use connectors or reducers in the air hose hook-up.
- For impact wrenches up to 1/2" drive and most other air tools a compressor with a minimum 20 gallon tank and 5 HP motor should be used. For 3/4" & 1" impact wrenches, sanders and heavy grinders a compressor with a minimum 40 gallon tank and 8 HP motor should be used. Note that all pro auto service shops have installed compressors that well exceed the above minimums.

Tips To Maximize Tool Life:

An air motor is no different than the internal combustion engine in your car, they need oil. Inline lubricators are best. If not installed always add a few drops of air tool oil into the tools air inlet each day before use, and most importantly at the end of the day add a few drops of air tool oil, run the tool for a few seconds before storing overnight.

In certain conditions compressed air generates water vapor that if entering the tool will corrode the internal motor parts, moisture traps should be fitted in to your air supply system.

Impact wrench hammer mechanisms require grease, normally it is adequate to replace the grease at the tools service interval or after six months use.

SERVICE / PARTS

STATE/PROVINCE	CITY	REPAIR CENTER	ADDRESS	ZIP	PHONE	FAX
Alabama	Birmingham	Tool-Smith	1300 4th Ave South	35233	205.323.2576	205.323.9060
Alabama	Mobile	Tool-Smith	927 Lakeside Drive	36693	251.661.0404	251.661.8970
Alberta	Stony Plain	Duke's Air Tool Repair	232, 3400 48 Street	T7Z 1W2	780.907.1392	780-591-4008
British Columbia	Burnaby	Westcoast Tool Sales & Repair	4008 Myrtle Street	V5C 4G2	604.873.5394	604.873.5313
British Columbia	Richmond	B.B. Tool Repair	12900 Jack Bell Road, Unit 1	V6V 2V8	604.303.0131	604.303.0134
California	Visalia	CTS&S Airtool Repair	1805 E Main St Bldg. E	93292	559.623.2157	559.734.4148
Florida	Spring Hill (Tampa)	R&R Tool Repair, Inc.	13637 Linden Drive	34609	352.263.3587	352.200.7587
Georgia	Marietta	Tool Service Company	178 Marble Mill Road	30060	404.524.4249	770.908.8082
Georgia	Norcross	Tool Smith	5600 Oakbrook Pkwy. #140	30093	770.448.4844	770.448.7395
Illinois	Elk Grove Village	Illinois Tool Service	1485 Landmeier Unit J	60007	847.228.1902	847.228.1913
Indiana	Indianapolis	VAMACO	6718 East 38th Street	46226	317.632.2208	317.244.3920
Kansas	Salina	Tool Time	420 N Santa Fe Ave.	67401	785.833.5236	NA
Kentucky	Louisville	Tool Repair Service, Inc.	1200 Goss Ave.	40217	502.635.6888	502.634.1931
Louisiana	Des Allemauds	Bayou Tool Service	4046 US 90 East	70030	985.758.3700	985-758-3517
Louisiana	Shreveport	Shreveport Air Tool, Inc.	125 Freestate Blvd.	71107	318.227.9412	318.227.0013
Michigan	Grand Rapids	Gezon Tool Service	322 Rumsey SW	49503	616.451.2725	616.451.2728
Michigan	Detroit	Billow Company	15335 Dale Street	48223	313.255.4446	313.255.4664
Michigan	Garden City	Midwest Tool Soutions	29931 Hennepin Street	48135	313.903.5203	734.427.0978
Minnesota	Bloomington	Delegard	9141 Lyndale Ave. S	55987	800.328.2897	952.884.5030
Minnesota	Cyrus	Air Tool Clinic	106 West Main Street	56323	320.795.2221	320.795.2221
Minnesota	Maple Grove	Tool Warehouse, Inc.	19520 County Road 81	55374	763.428.4260	763.428.4270
Minnesota	St. Cloud	Tool Warehouse Inc	9 Lincoln Ave. SE	56304	320.253.7150	320.253.5905
Missouri	Blue Springs	Clark's Tool & Equipment	815 W 40 Hwy.	64015	816.228.9885	816.228.2062
Nebraska	Omaha	Thacker Electric Co.	8517 I Street	68127	402.592.9433	402.592.3768
New York	Brooklyn	Five Boro Pneu-Tronics	801 East 42nd Street	11210	718.338.8911	718.338.8914
New York	Syracuse	Ace Hydraulic Service	6720 VIP Pkwy.	13211	315.454.8989	315.455.9522
North Dakota	West Fargo	Tool Warehouse Inc	127 Main Ave. West	58078	701.282.6151	701.282.6083
Ohio	Tallmadge	Power Tool Repair, Inc.	371 West Ave.	44278	330.630.0022	330.630.3320
Ohio	Cleveland	Tri County Power Tool	1300 Brookpark Rd.	44109	866-873-8278	516.398.6121
Oklahoma	Oklahoma City	Hydraulic Equipment	2800 W. California Ave.	73107	405.235.3310	405.232.4722
Ontario	Toronto	HT Pneumatic Rebuilders	22 Goodmark Place, Unit 8	M9W 6R2	416.407.5739	416.213.9357
Oregon	Milwaukie	Charles H Day Co	11405 SE 37th Ave.	97222	503.972.6771	503.972.6772
Pennsylvania	Hanover	Contract Tool Repair	126 Rear Carlisle Steet	17331	717-630-1202	N/A
Pennsylvania	Lititz	PaulB LLC	50 Wood Corner	17543	717.738.7350	717.738.7360
Quebec	Gatineau	L'entrepot D'outillage	156 rue de Varennes	J8T 8G4	819.771.9393	819.771.2745
Tennessee	Chattanooga	Tools & Hydraulics	910-C Creekside Rd	37422	423.622.8282	423.629.0125
Tennessee	Nashville	Tool-Smith	665 Massman Drive	37210	615.883.4833	615.883.4236
Texas	Deer Park	Power Tool Service and Supply	1213 Georgia Ave.	77536	713.228.0100	281.476.9810
Texas	Laredo	Worldwide Automation	920 Santa Maria Ave.	78040	956.727.0441	856.723.6258
Washington	Spokane Valley	Air Electric Equipment and Tools, Inc	5603 E 3rd. Ave.	99212	800.348.8337	509.534.3752
Wisconsin	New Berlin	Professional Tool Center	16333 W.Rogers Dr.	53151	262.432.9307	N/A
Wisconsin	Greenbay	Power Tool Service Co.	1180 Ashwaubenon Street	54304	920.983.4480	920.983.4490

AIRCAT WARRANTY



AIRCAT and NITROCAT® air tools are warrantied to be free from defects in material and workmanship for 2 years from date of purchase. We will repair or replace; at our option any defective part or unit which proves to be defective in material or workmanship during this 2 year period.



VIBROTHERM DRIVE® air tools and our low weight 1" impact series models (1991, 1991-1 and 1870-P) are warrantied to be free from defects in material and workmanship for 3 years from date of purchase. We will repair or replace; at our option any defective part or unit which proves to be defective in material or workmanship during this 3 year period.

The foregoing obligation is AIRCAT and Florida Pneumatic's sole liability under this or any implied warranty, under no circumstances shall it be liable for any incidental or consequential damages.

This warranty applies to the tool only. This warranty does not apply to any attached accessories/ consumable products; such as drill chucks, sander backing pads, air hammer retainers and chisels or "kit" accessories or any other accessory included with the tool.

Any repair required due to normal wear and tear, abuse, misuse, modification of the tool or repair attempts (by other than an AIRCAT® or Florida Pneumatic Authorized Service Center) are not covered by this warranty.

Return your tool to an AIRCAT® or Florida Pneumatic Authorized Service Center freight prepaid. Be sure to include your name, address, copy of purchase with date and description of the suspected defect.

AIRCAT® whose policy is continued product improvement reserves the right to make changes in design or construction at any time without incurring any obligation on tools previously sold.

INDUSTRY ASSOCIATIONS





000AC10
REV2020



AIRCAT

a Division of Florida Pneumatic
Manufacturing Corporation
851 Jupiter Park Lane Jupiter, Florida 33458
Toll Free (800) 356-3392 | Fax (561) 575-9134
www.aircat.com

Distributed by: